

# Slip Ring Assemblies



**CONDUCTIX**  
wampfler

DELACHAUX GROUP



# Contents

---

<b>General</b>	5
Electrical Data .....	5
Example of a Combined Slip Ring Assembly.....	6
A Developed and Comprehensive Standard Program .....	7
<hr/>	
<b>Modular Slip Rings</b>	8
CER 50-70-90-91 .....	8
CEQ 70-90-91-130-131-190-191 .....	9
CEP 70-90 .....	10
CEP/SB .....	11
MME 35-50 .....	12
MCS 35-50 .....	13
MINOR .....	14
CGR 200-270 .....	15
<hr/>	
<b>Fixed Size Slip Rings</b>	16
CEPE .....	16
CEPE/5 .....	17
CEE .....	18
<hr/>	
<b>ATEX Slip Rings</b>	19
ARIETE Ex d IIB T5 II 2G ATEX .....	19
STAR 0, STAR 1, STAR 2, STAR 3 Ex d I I M2 ATEX.....	20
SXD SERIES – ATEX –  II 2D Ex tD A21 IP65 T 80 °C .....	21
<hr/>	
<b>Slip Rings for Data Transmission</b>	22
ETH/F-ETH/G .....	22
IndEth 100/IndEth 1000 .....	23
<hr/>	
<b>Fiber Optic Rotary Joints (FORJ)</b>	24
Fiber Optic Rotary Joints .....	24
<hr/>	
<b>Custom-built Slip Rings</b>	26
Custom-built Slip Rings for Power and Data Transmission .....	26
<hr/>	
<b>Questionnaire</b>	30

---

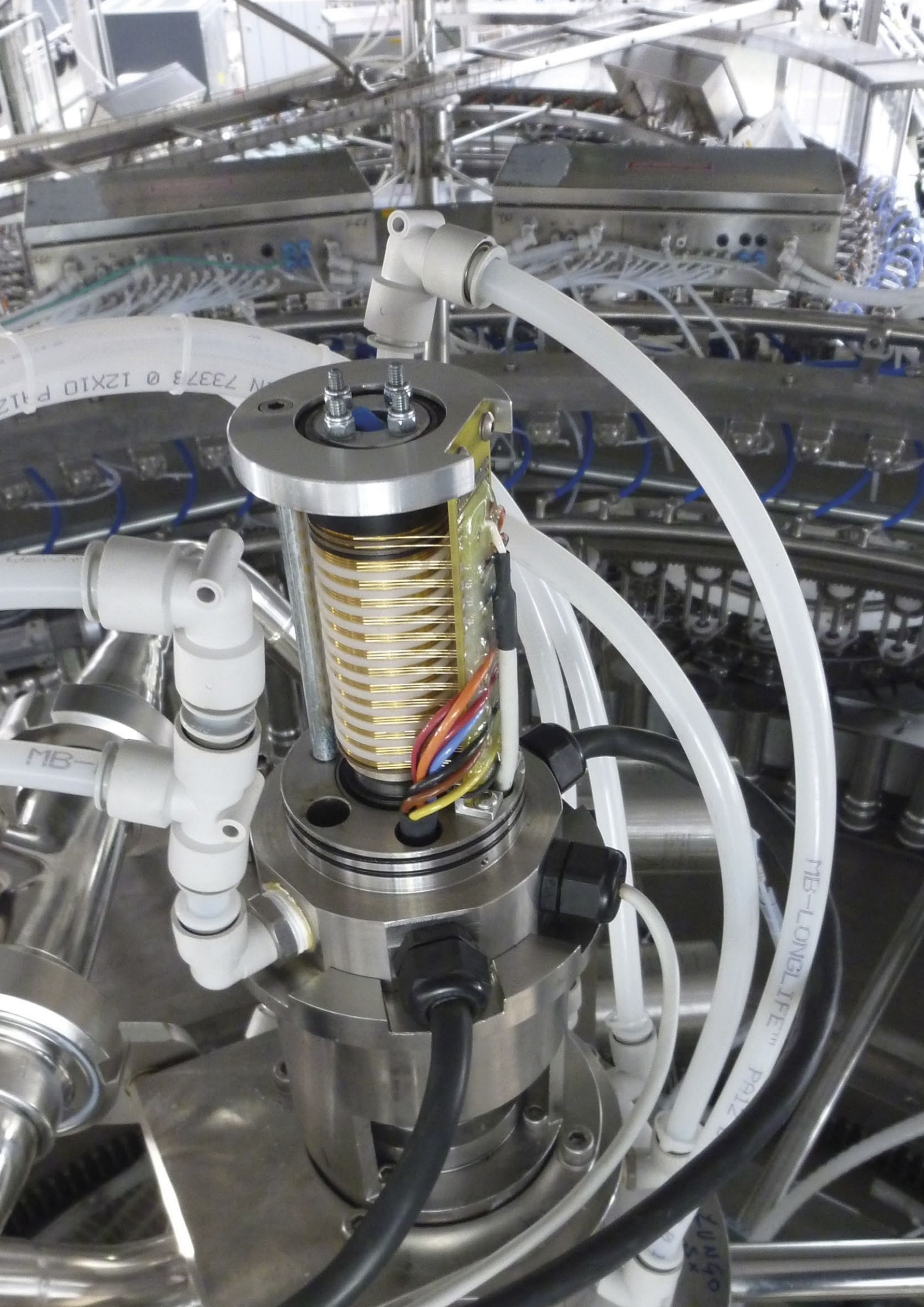

N 73373 Ø 12X10 PA12

MB-

MB-LONG LIFE™ PA12

10N90

# General

---

## Electrical Data

---

### Conductix-Wampfler – an experienced partner

Conductix-Wampfler offers a wide range of rotary transmissions for energy, data and signal transmission, as well as for the transmission of gases and fluids.

The standard program provides Slip Ring Assemblies for power and data/signal currents with any number of poles. Combinations that include additional rotary transmissions for liquids (water, hydraulic oil, oil, etc.) and gases (compressed air, argon, etc.) are possible. Slip Ring Assemblies can be either supplied as components that can be built into the host machine and adjusted to the customers' requirements or with a housing of impact resistant plastic or steel.

### Data transmission

- Transmission of analog and digital signals is used in several industrial applications as well as in many other areas
- Communication rings will pass all standard transmission protocols
- Depending on the application, different materials are used for the slip rings

**Note:** The quality of transmission of the analog-to-digital signals highly depends on the quality of the complete system, of which the SRA (Slip Ring Assembly) is only a part. An important role is also played by the cables, their construction and shielding. The number of cable connections, external interference, the type of automation devices, and their adaption to each other are also important factors. These should be considered when specifying the complete system.

### Options

- Internal heaters to eliminate condensation in humid locations
- Installation of encoders and potentiometers
- Transparent windows and doors on the larger enclosures to aid maintenance

### Special constructions

Our experts are available to advise you concerning any special requirements, such as assemblies with large diameters, extreme operating conditions, units that incorporate fiber optic swivels, and units designed for high voltages.

### Easy assembly and maintenance

Our Slip Ring Assemblies are easy to install and maintain. By special request, rings and brush holders can be delivered completely pre-wired, using built-in terminal boxes and terminal strips. All connections are easy to access and the brushes are easy to replace.

### Engineering standards

All Slip Ring Assemblies built by Conductix-Wampfler employ the latest technologies available. We conform to the strictest requirements of low voltage directives.

# General

## Example of a Combined Slip Ring Assembly

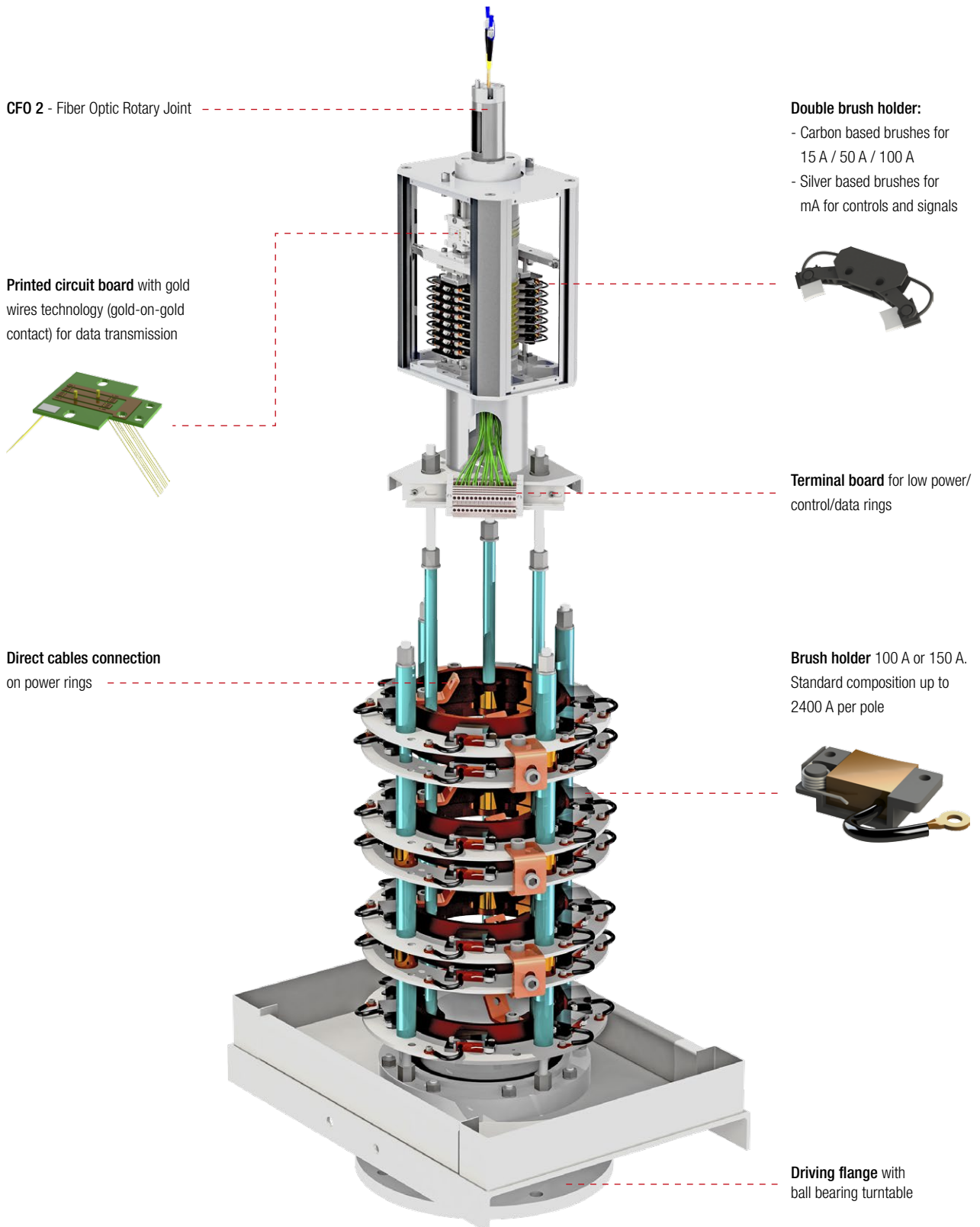

# General

---

## A Refined and Comprehensive Standard Program

---

Some examples of slip ring applications:



Wrapping machine



Transfer machine



Stacker/Reclaimer with large bore slip ring

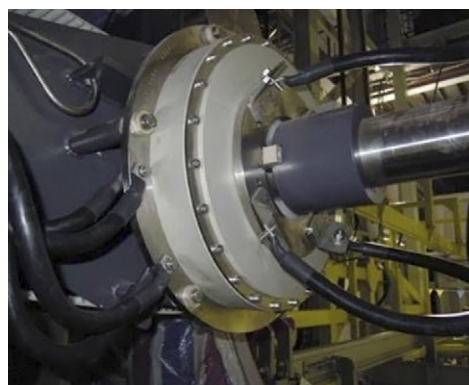
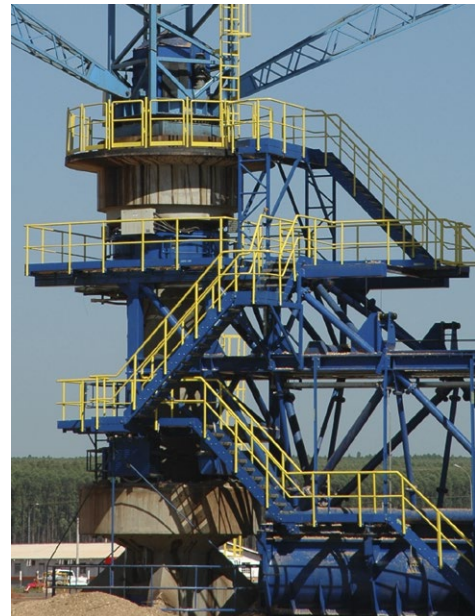

Slip Ring in an electrophoresis plant



Slip Ring in an amusement ride

# Modular Slip Rings

## CER 50-70-90-91

CER Series Slip Rings are produced in various sizes to meet the needs of each user and application. They are designed to be freely configured, allowing many possible compositions, and combine rings for high and low power, digital and analog signals, and data communication up to Real Time Ethernet 100 Mbps into a single product.

The special attention in the design phase and the solution adopted for CERs, allow the applicability of these in areas in which high technical performances, reliability and capability to withstand hard working cycles are needed. Usually these products are applied on automatic machines for high-volume production like machine tools, rotary tables, packaging/labeling machines, and filling machines, etc.

### General Characteristics

Slip Ring type:	Modular
Size:	CER 50 - CER 70 - CER 90 - CER 91
Version:	Blind (C) and Through bore (P)
Pole function:	Power up to 300 A, auxiliary and low data rate signals Data transmission up to 100 Mbps
Max. voltage:	400 V (AC) - 230 V (AC)
Test voltage:	According to IEC 60947-1
Max. current:	300 A
Protection class:	IP54
Max. rotational speed:	100 rpm
Mounting position:	Vertical/horizontal
Working temp.:	+5 °C to +45 °C
Rotation sense:	Clockwise/counterclockwise

### Standard Construction

Material:	Natural anodized aluminum
Ring material:	Brass for power Silver- or gold-plated brass for signals and data
Brush material:	Copper alloy brushes for power Silver alloy brushes for signal and data Gold wire technology for data
Screw material:	Galvanized steel
Rotary shaft:	2 ball bearings sealed and lubricated for life
Protection sheath:	Polypropylene
Cables:	2 m of unipolar cables, already connected to rings
Nameplate position:	On back head of Slip Ring body

### Options

Cable glands and cabling on brushes:	Single core shielded, special lengths on request
Fixing accessories:	For rotor and stator
Terminal board:	For rings cabling
Heating elements:	15 W, 20 W, 30 W and 50 W Voltage 24 V (DC), 110/220/230 V (AC)
Cables:	Special cables or customer cables by request
Connectors:	Cables with connectors or connectors on the body of the Slip Ring on both ring and brush sides
Fluidic Joints:	Applicable with special construction

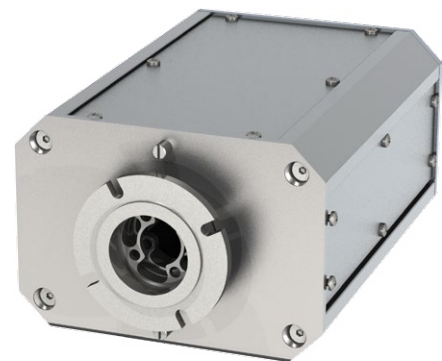
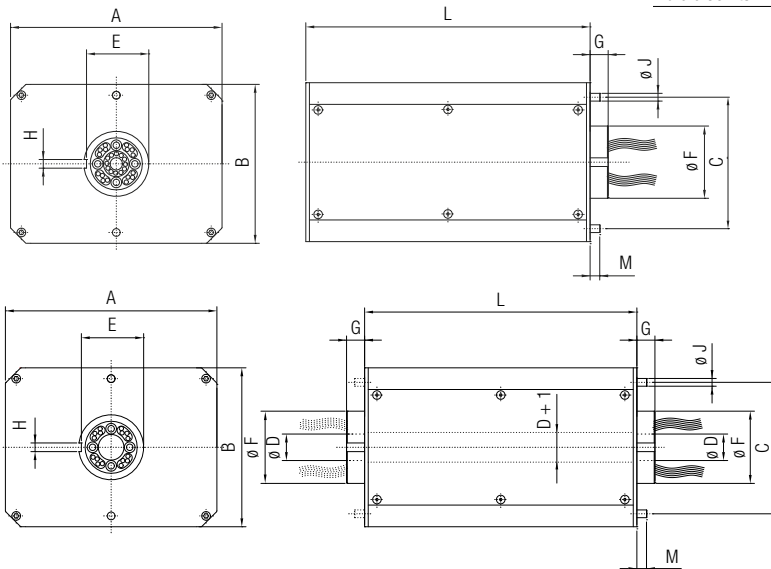

Size	Dimensions [mm]									Blind		Through	
	A	B	C	E	F	G	J	M	H	D	L max.	D	L max.
CER 50	180	125	105	56	59 h8	22	8 h8	10	10	11.5	700	24 H8	440
CER 70	200	150	125	76	79 h8	22	10 h8	10	10	18.5	900	39 H8	700
CER 90	220	170	145	95	99 h8	22	12 h8	12	12	24	1100	49 H8	900
CER 91	300	220	190	95	99 h8	22	12 h8	12	12	24	1300	49 H8	1000



# Modular Slip Rings

## CEQ 70-90-91-130-131-190-191

CEQ Series Slip Rings are produced in various sizes to meet the needs of each user and application. The square external shape allows easy connections to brush holders by simply removing the external panels, while also maintaining compact external dimensions. They can be configured with rings for high and low power, digital and analog signals, as well as data communication up to Real Time Ethernet 100 Mbps.

The special attention in the design phase and the solution adopted for CEQs, allow the applicability in areas in which high technical performance, reliability and capability to withstand demanding working cycles are crucial. Usually these products are applied on automatic machines for high-volume production like machine tools, rotary tables, spindles, packaging/labeling machines, and filling machines, etc. CEQs, like most Conductix-Wampfler electrical slip rings, are suitable to be coupled with fluidic rotary Joints.

### General Characteristics

Slip Ring type:	Modular
Size:	CEQ 70 - CEQ 90 - CEQ 91 CEQ 130 - CEQ131 - CEQ 190 - CEQ 191
Version:	Blind (C) and Through bore (P)
Pole function:	Power up to 300 A, auxiliary and low data rate signals Data transmission up to 100 Mbps
Max. voltage:	400 V (AC) - 230 V (DC)
Test voltage:	According to IEC 60947-1
Max. current:	300 A
Protection class:	IP54
Max. rotational speed:	100 rpm
Mounting position:	Vertical/horizontal
Working temp.:	+5 °C to +45 °C
Rotation sense:	Clockwise/counterclockwise

### Standard Construction

Material:	Natural anodized aluminum
Ring material:	Brass for power Silver- or gold-plated brass for signals and data
Brush material:	Copper alloy brushes for power Silver alloy brushes for signal and data Gold wire technology for data
Screw material:	Galvanized steel
Rotary shaft:	2 ball bearings sealed and lubricated for life
Cables:	2 m of unipolar cables, already connected to rings
Nameplate position:	On back head of Slip Ring body

### Options

Cable glands and cabling on brushes:	Single core shielded, special lengths on request
Fixing accessories:	For rotor and stator
Terminal board:	For rings cabling
Heating elements:	15 W, 20 W, 30 W and 50 W Voltage 24 V (DC), 110/220/230 V (AC)
Connectors:	Cables with connectors or connectors on the body of the Slip Ring on both ring and brush sides
Fluidic Joints:	Applicable with special construction

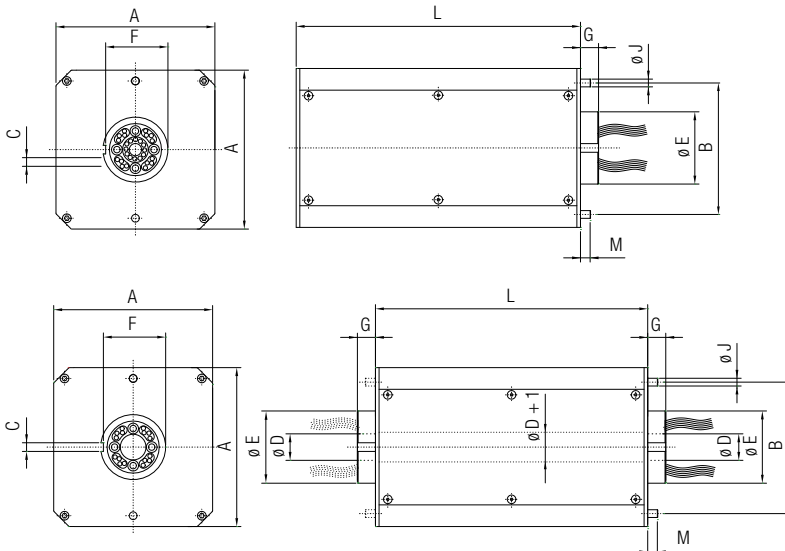

Size	Dimensions [mm]								Blind		Through	
	A	B	C	E	F	G	J	M	D	L max.	D	L max.
CEQ 70	150	125	10	79 h8	76	22	10 h8	10	18.5	900	39 h8	700
CEQ 90	170	145	12	99 h8	95	22	12 h8	12	24	1150	49 h8	900
CEQ 91	220	190	12	99 h8	95	22	12 h8	12	24	1300	49 h8	1000
CEQ 130	270	240	16	139 h8	133	25	12 h8	12	-	850	99 h8	850
CEQ 131	270	240	16	139 h8	133	25	12 h8	12	-	1300	79 h8	1300
CEQ 190	330	300	18	209 h8	203	25	12 h8	12	-	1000	159 h8	1000
CEQ 191	330	300	18	209 h8	203	25	12 h8	12	-	1500	124 h8	1500

# Modular Slip Rings

## CEP 70-90

CEP Series Slip Rings are produced in various sizes to meet the needs of each user and application. The circular external body is compact. CEP Slip Rings are widely used where high technical performance, reliability, and capability to withstand demanding working cycles are needed.

Usually these products are applied on automatic machines for high-volume production like machine tools, rotary tables, spindles, packaging/labeling machines, and filling machines, etc.

CEPs, like almost all Conductix-Wampfler electrical Slip Rings, can be coupled with fluidic rotary joints.

### General Characteristics

Slip Ring type:	Modular
Size:	CEP 70 - CEP 90
Version:	Blind (C) and Through bore (P)
Pole function:	Power up to 200 A, auxiliary and signal Data transmission up to 100 Mbps
Max. voltage:	400 V (AC) - 230 V (DC)
Test voltage:	According to IEC 60947-1
Max. current:	200 A
Protection class:	IP54
Max. rotational speed:	100 rpm
Mounting position:	Vertical/horizontal
Working temp.:	+5 °C to +45 °C
Rotation sense:	Clockwise/counterclockwise

### Standard Construction

Material:	Natural anodized aluminum
Ring material:	Brass for power Silver plated or gold plated brass for signals and data
Brush material:	Copper alloy brushes for power Silver alloy brushes for signal and data Gold wire technology for data
Screw material:	Galvanized steel
Rotary shaft:	2 ball bearings, sealed and lubricated for life
Cables:	2 m of unipolar cables, already connected to rings
Nameplate position:	On top of the cover

### Options

Cable glands and cabling on brushes:	Single core shielded, special lengths by request
Cable on rings:	Length different from standard construction length (2 m)
Fixing accessories:	For rotor and stator
Terminal board:	For rings cabling
Heating elements:	15 W, 20 W, 30 W and 50 W Voltage 24 V (DC), 110/220/230 V (AC)
Cables:	Special cables or customer cables by request
Connectors:	Cables with connectors or connectors on the body of the Slip Ring
Fluidic Joints:	Applicable with special construction
Fiber Optic Rotary Joints:	Applicable with special construction

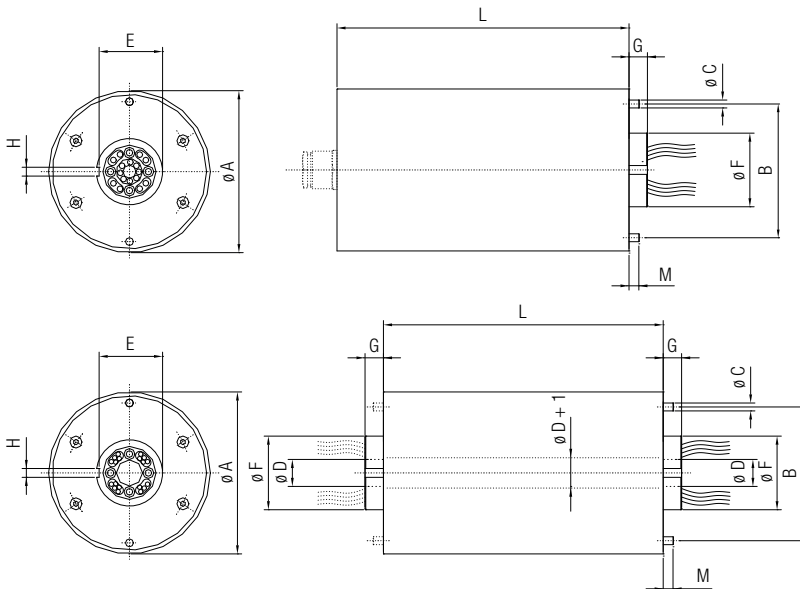

CEP	Size	Dimensions [mm]									
		A	B	C	D	E	F	G	H	M	L max.
Blind Version	CEP 70 / C	170	125	10 h8	-	76	79 h8	22	10	10	463
	CEP 90 / C	200	145	12 h8	-	95	99 h8	22	12	12	837
Through Hole Version	CEP 70 / P	170	125	10 h8	39 h8	76	79 h8	22	10	10	463
	CEP 90 / P	200	145	12 h8	49 h8	95	99 h8	22	12	12	837

# Modular Slip Rings

## CEP/SB

CEP/SB series Slip Rings are produced in several sizes, up to a maximum of 36 rings to meet customer needs.

CEP/SB series Slip Rings can be used for transmitting power, auxiliary, signals, and data.

The round shape and high reliability of this product make CEP/SB series suitable to be used on earthmoving equipment, turntables, packaging machines, and in water treatment plants, etc.

CEP/SB Slip Rings are particularly suited for being equipped with fluidic rotary joints.

### General Characteristics

Slip Ring type:	Modular
Size:	12 – 24 – 36 rings
Pole function:	Power up to 100 A, auxiliary, signals and data
Max. voltage:	600 V (AC) – 220 V (DC)
Test voltage:	According to IEC 60947-1
Max. current:	100 A
Protection class:	IP55
Max. rotational speed:	50 rpm
Mounting position:	Vertical/horizontal
Working temperature:	+5 °C to +45 °C
Rotation sense:	Clockwise/counterclockwise

### Standard Construction

Body and cover material:	Anodized aluminum
Ring material:	Brass (power) Gold plated or silver plated brass (signal and data)
Brush material:	Copper graphite (power) Silver alloy (signal & data)
Mechanical parts and screws:	Galvanized steel
Rotary shaft:	2 ball bearings sealed and lubricated for life
Cables:	2 m on ring side
Nameplate position:	On the top of the cover

### Options

Cabling on brushes – Special Cables – Connectors – Flange – Terminal board for rings under the cover – Heating elements – Fluidic Joints

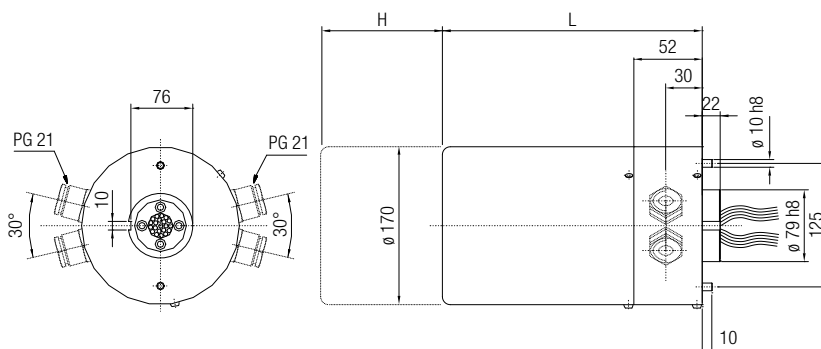

Size	Max. number of 15 A rings	Max. number of 50 A rings	Max. number of 100 A rings	Max. rings + insulators total height [mm]	L [mm]	H [mm]
CEP/SB/701	12	8	4	68	150	95
CEP/SB/702	24	16	4	136	220	165
CEP/SB/703	36	24	4	204	285	230

# Modular Slip Rings

## MME 35-50

The MME series is a reliable, cost-effective and proven series of products that seeks to provide the consumer with maximum efficiency. A very versatile slip ring due to its unique compactness. These slip rings are suitable for signals or power passage up to a maximum of 12 A. MME slip rings are widely used for packaging, labeling and filling machines.

### General Characteristics

Slip Ring type:	Modular
Size:	30 Rings 12 A
Pole function:	Low power, auxiliary, signal, data
Max. voltage:	400 V
Test voltage:	According to IEC 60947-1
Max. current:	12 A
Protection class:	IP55
Max. rotational speed:	50 rpm
Mounting position:	Vertical/horizontal
Working temp.:	+5 °C to +45 °C
Rotation sense:	Clockwise/counterclockwise

### Standard Construction

Material:	Anodized Aluminum
Ring material:	Brass for power Silver plated or gold plated for signals and data
Brush material:	Copper alloy brushes for power Silver alloy brushes for signals and data
Screw material:	Galvanized steel
Cables:	Unicore cables, already connected to rings
Nameplate:	Positioned on the top of the cover

### Options

Protection class IP65 – AISI 304 – AISI 316L

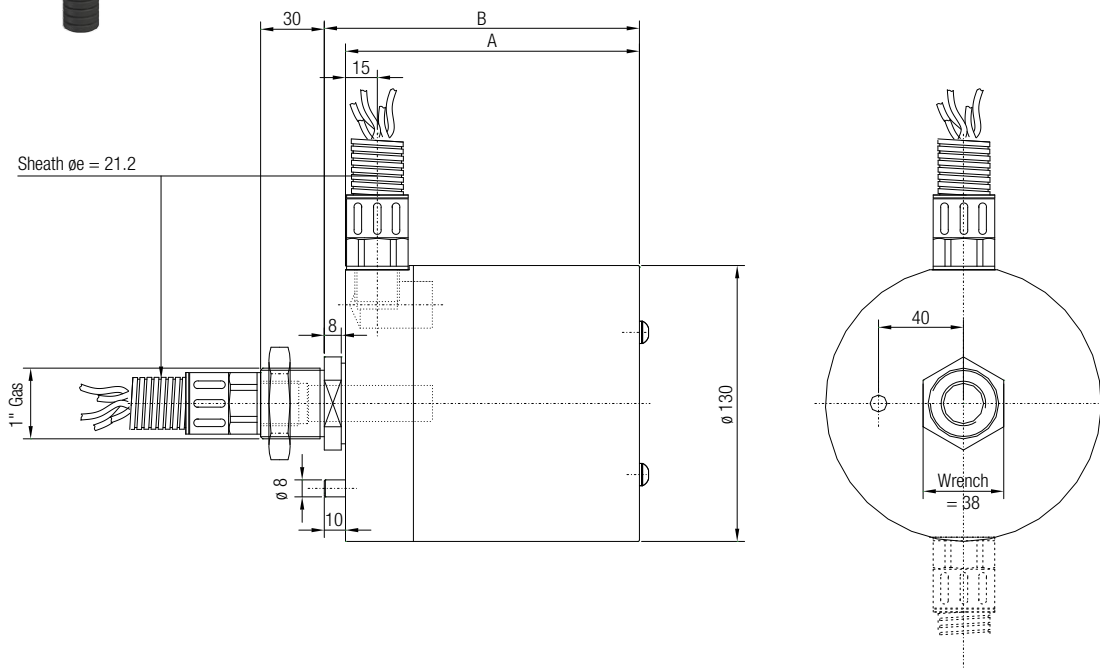

# Modular Slip Rings

## MCS 35-50

MCS 35 – MCS 50 Slip Rings are high performance devices for the transmission of low power and data.

This model of Slip Ring includes gold-on-gold sliding contacts that ensure long life without any maintenance due to the particular lubricant used.

It is completely made of stainless steel (also AISI 316L available) and with IP67 protection.

All these characteristics make it perfect to be used in applications where robustness, high reliability, and demanding working cycles of 24 hours/day are requested, such as for filling machines in the food and beverage market.

### General Characteristics

Max. composition:	7 rings 10 A + 11 rings 2 A (for MCS35) 7 rings 12 A + 20 rings 2 A (for MCS50)
Pole function:	Low power, auxiliary, signal, data
Max. voltage:	400 V
Test voltage:	According to IEC 60947-1
Max. current:	10 A
Protection class:	IP67
Max. rotational speed:	50 rpm
Mounting position:	Vertical/horizontal
Working temperature:	+5 °C to +45 °C
Rotation sense:	Clockwise/counterclockwise
Sliding contact life:	10,000,000 cycles

### Standard Construction

Body and cover material:	Stainless steel
Ring material:	Gold plated brass
Brush material:	Gold plated copper (power) Gold alloy (signal)
Mechanical parts and screws:	Stainless steel
Max. outputs:	3 x Pg11
Cables:	2 m on both rings and brushes
Nameplate position:	On the crankcase

### Options

AISI 316L – Special cables – Slip Rings with different lengths and configurations

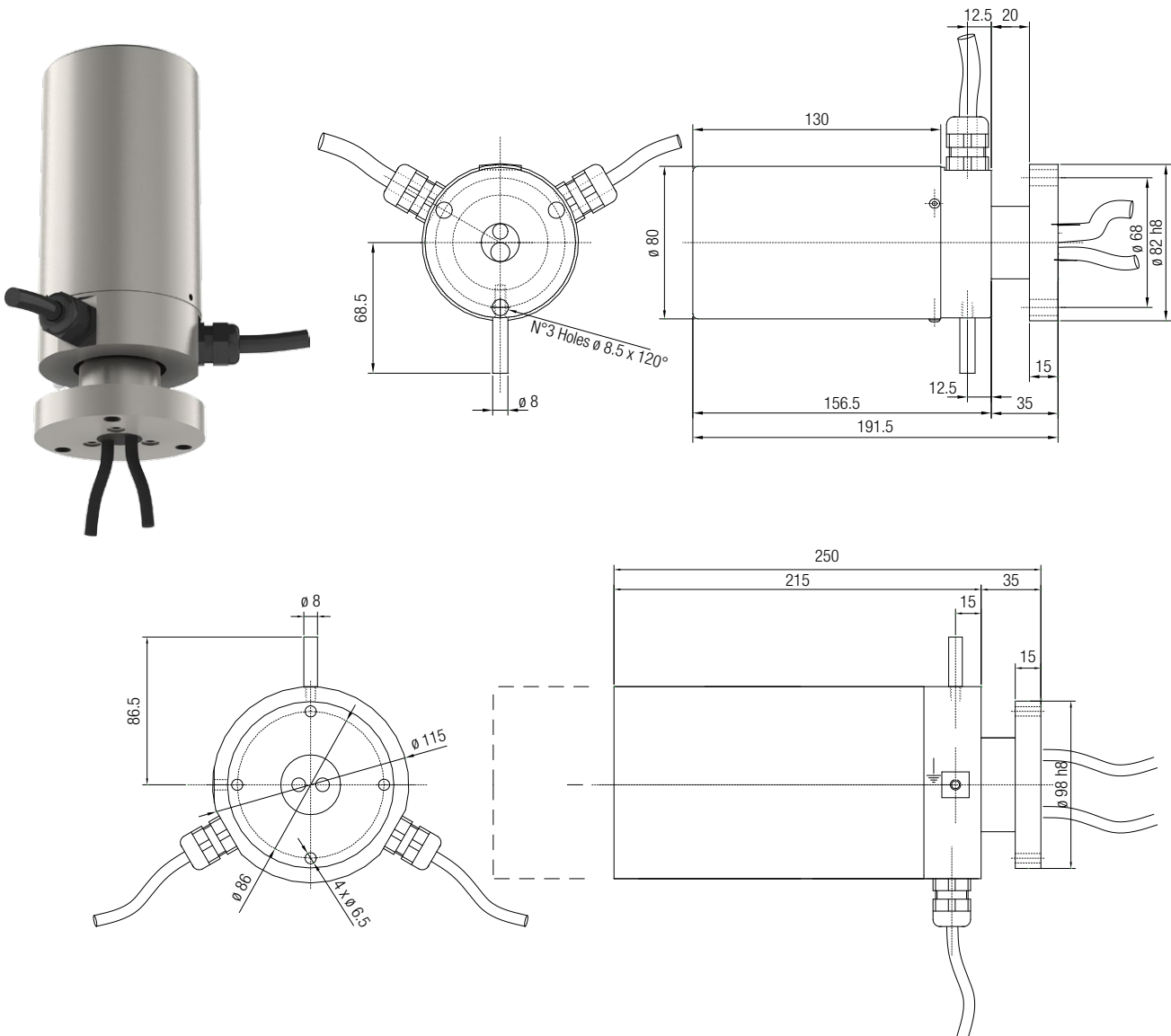

# Modular Slip Rings

## MINOR

Conductix-Wampfler introduces the Minor Slip Ring series with ring variety ranging anywhere from 2 to 24 rings. This convenient and unique Slip Ring can be modified and tailored to the customers' requirements. The Slip Rings can be assembled with a maximum of 24 rings at 20 Amps capacity.

The Minor series provides the user with the choice of a pre-wired cable leads of either 1.5 mm<sup>2</sup> or 2.5 mm<sup>2</sup>.

The tandem mounted brushes maintain continuous contact and maintain self cleaning throughout the use of the product in order to keep everything constantly moving with as little interruption as possible.

The efficiency of the Minor is improved by featuring a facilitative one-piece lift-off cover which permits easy access.

In addition to the standard model, Conductix-Wampfler offers the option to install a fluid coupling at the base.

### General Characteristics

Slip Ring type:	Modular
Size:	Minor 2-24 rings
Max. voltage:	600 V
Test voltage:	According to IEC 60947-1
Max. current:	100 A
Protection class:	IP55
Max. rotational speed:	30 rpm
Mounting position:	Vertical/horizontal
Working temp.:	+5 °C to +45 °C
Relative humidity:	90% without condensation
Rotation sense:	Clockwise/counterclockwise

### Standard Construction

Material:	Aluminum
Ring material:	Bronze
Brush material:	Metal-Carbon
Screws material:	Galvanized steel
Rotary shaft:	Galvanized steel
Cables:	2 m of unicore cables on ring side
Sheath:	Polypropylene
Fittings material:	Galvanized steel
Nameplate:	Positioned on the slip ring body

### Options

IP65 or IP67 protection class - Fluidic joint - Special cables - Terminal boards on rings

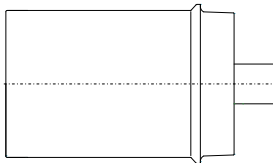

Standard model

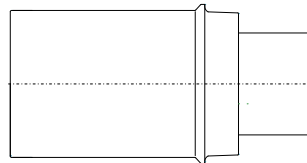

Model with Sliprings + fluid coupling at base

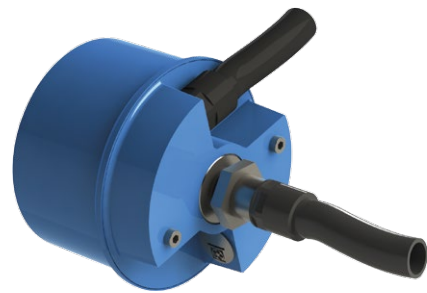

Type	No. of rings	Length x
MINOR 2	2	100
MINOR 3	3	
MINOR 4	4	
MINOR 5	5	140
MINOR 6	6	
MINOR 7	7	
MINOR 8	8	
MINOR 9	9	
MINOR 10	10	185
MINOR 11	11	
MINOR 12	12	
MINOR 13	13	
MINOR 14	14	
MINOR 15	15	225
MINOR 16	16	
MINOR 17	17	
MINOR 18	18	
MINOR 19	19	
MINOR 20	20	265
MINOR 21	21	
MINOR 22	22	
MINOR 23	23	
MINOR 24	24	

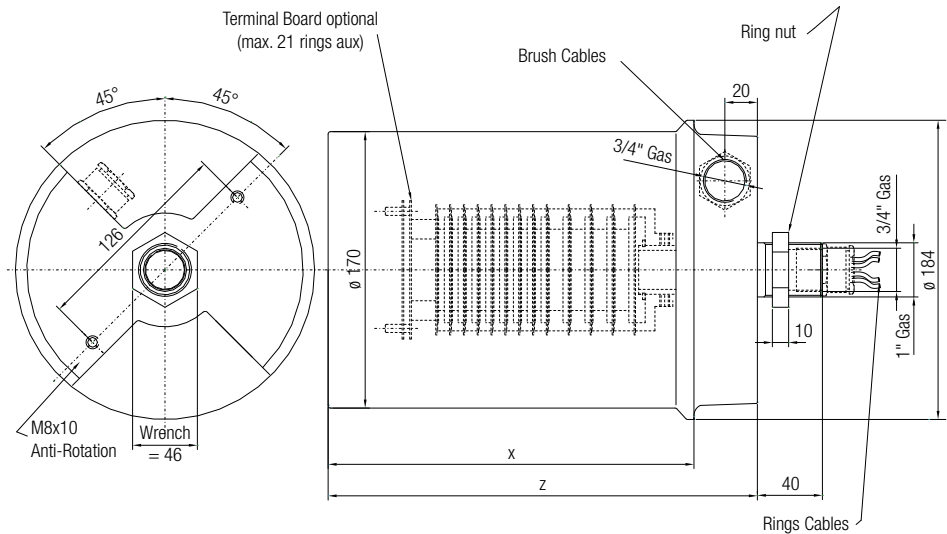

# Modular Slip Rings

## CGR 200-270

CGR Series Slip Rings are produced in two sizes to meet the needs of each user and application. The CGR series can accommodate high and low power, control, and signal/data within the same slip ring. Generally the low power and data/signal section is contained within a CER series Slip Ring inside the CGR. CGR 270 can be provided also with a medium voltage section. The Slip Ring is supplied with low voltage and signals rings pre-wired directly to a terminal board positioned inside the slip ring box. For high-power rings, it is possible for the customer to wire his own cables directly to rings and brush holders. The CGR Slip Ring series is highly appreciated for its great reliability owing to a good robustness and easy accessibility for periodic maintenance. These are typically used on port rotary cranes.

### General Characteristics

Slip Ring type:	Modular
Size:	CGR 200 – CGR 270
Poles function:	Power up to 300 A, auxiliary and low rate signals Data transmission up to 1Gbps
Max. voltage:	Low voltage up to 1000 V Medium voltage up to 24000 V
Max. current:	300 A
Protection class:	IP55 (depending on the mounting)
Max. rotational speed:	30 rpm
Mounting position:	Vertical
Working temp.:	+5 °C to +45 °C
Rotation sense:	Clockwise/counterclockwise

### Standard Construction

Body material:	Grey painted RAL 9006 steel
Inspection doors:	Wide and removable on opposite sides
Ring material:	Bronze or brass for power Silver-/gold-plated brass for signals
Brush material:	Copper-graphite brushes for power Silver-based brushes or gold wires for signal and data
Screw material:	Galvanized steel
Inspections doors:	Wide and removable on opposite sides
Rotary shaft:	2 ball bearings sealed and lubricated for life
Cables:	Single core cables 2 m length
Rotating shaft:	On ball bearings
Protection sheath:	Polypropylene
Identification plate:	On the slip ring body

### Options

Special bigger size to meet requests for large slip ring assemblies	
Cabling on rings and brush holders:	Cable type and length on request
Cable glands:	By request
Heating elements:	100 W and 200 W, Voltage 220 V (AC)
Slip ring assembly and bolts and nuts:	Stainless steel
Slip ring assembly:	Special painting on demand
Fixing interface for encoder:	Inside or outside the slip ring body
Fiber Optic Rotary Joint:	Inside or outside the slip ring body
Fluidic joint:	By request, applicable with special construction

Available Lengths	
CGR 200 Low Voltage	CGR 270 Low Voltage - Medium Voltage
950	–
1160	–
1370	1370
1580	1580
1790	1790
2000	2000
2210	2210
2420	2420

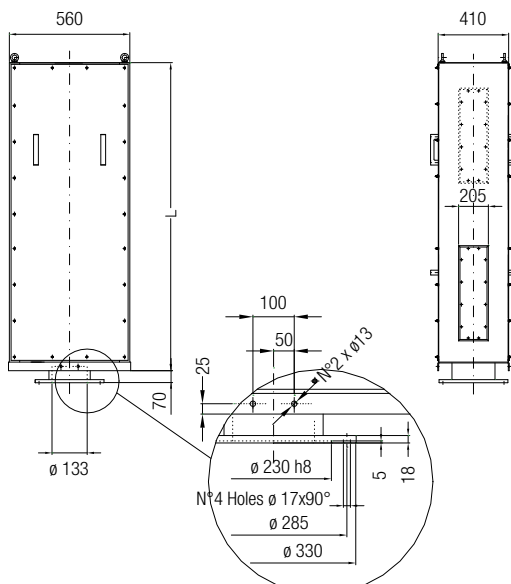

CGR 200 Low Voltage

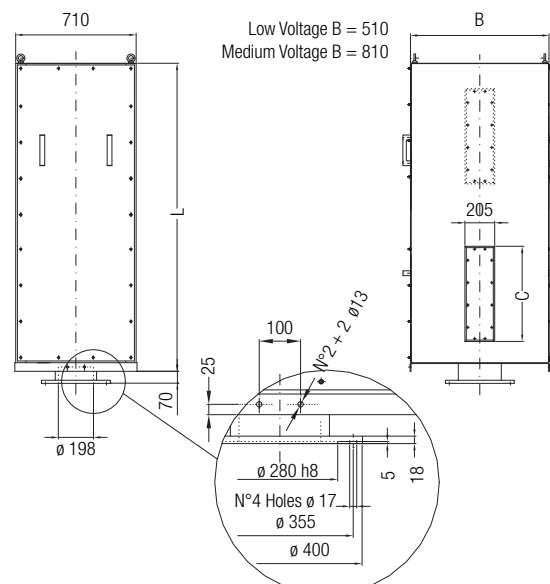

CGR 270 Low Voltage - Medium Voltage

# Fixed Size Slip Rings

## CEPE

CEPE Slip Rings are low cost, yet reliable products that are particularly suitable for applications with low revolutions per minute. Its high protection class (up to IP65) and plastic cover make it adaptable to outdoor environments, e.g. in mobile excavators or earth movers. CEPE is available in 3 fixed sizes, 7, 12, or 18 rings for transmitting low power or signals up to Profibus-DP. Due to its characteristics it is perfect for connections to fluidic rotary joints for the transmission of air, oil, or cooling liquid.

### General Characteristics

Number of poles:	7-12-18 rings
Pole function:	Auxiliary Low Power (12 A max.)
Max. voltage:	230 V (AC)
Test voltage:	According to IEC 60947-1
Max. current:	12 A
Protection class:	IP54
Max. rotational speed:	30 rpm
Mounting position:	Vertical/horizontal
Working temperature:	+5 °C to +45 °C
Rotation sense:	Clockwise/counterclockwise

### Standard Construction

Body and cover material:	Polyamide PA 66 black
Ring material:	Silver plated brass
Brush material:	Power: Copper graphite Signals: Silver alloy
Mechanical parts and screws:	Galvanized steel
Cables:	Unipolar 2 m on both rings and brushes
Sheath and fittings material:	Polypropylene
Nameplate position:	On the top of the cover

### Options

IP65 protection class – Special cables – Fluidic joint

Model	No. of rings	A [mm]	Weight [kg]	Cable sect. [mm <sup>2</sup> ]
CEPE 7	7	73	1.2	1.5
CEPE 12	12	100	1.3	1.5
CEPE 18	18	133	1.6	1.5

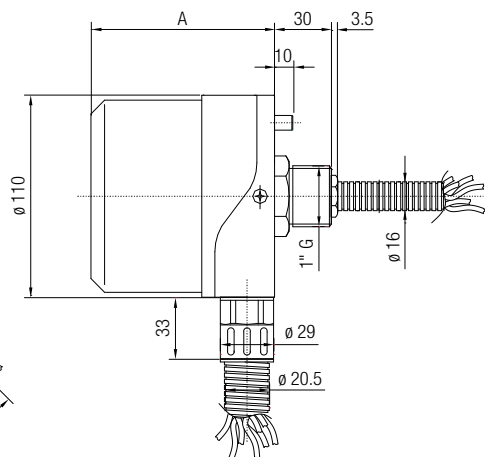
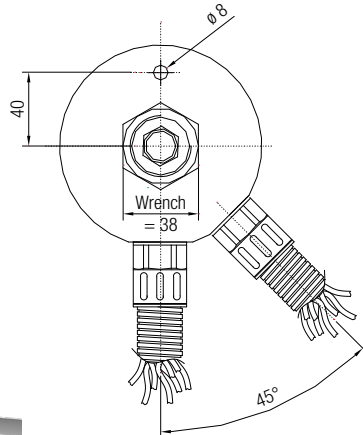



# Fixed Size Slip Rings

## CEPE/5

The CEPE/5 Slip Ring are a low cost, yet reliable product particularly suitable for applications with a high number of revolutions per minute guaranteed by its double ball bearing. CEPE/5 is able to go up to 600 rpm which allows for its application in machines in need of high productivity and efficiency. CEPE is available in 3 fixed sizes, with up to 8 rings.

### General Characteristics

Number of poles:	4-6-8
Pole function:	Auxiliary Low Power (12 A max.)
Max. voltage:	230 V (AC)
Test voltage:	According to IEC 60947-1
Max. current:	12 A
Protection class:	IP55
Max. rotational speed:	600 rpm
Mounting position:	Vertical/horizontal
Working temperature:	+5 °C to +45 °C
Rotation sense:	Clockwise/counterclockwise

### Standard Construction

Body and cover material:	Anodized aluminum
Ring material:	Gold plated or silver plated brass
Brush material:	Copper graphite (power) Silver alloy (signal)
Mechanical parts and screws:	Galvanized steel
Cables:	No cable, terminal board on both rings and brush holders
Sheath and fittings material:	Polypropylene - Polyamide
Nameplate position:	On the top of the cover

### Options

Special cables

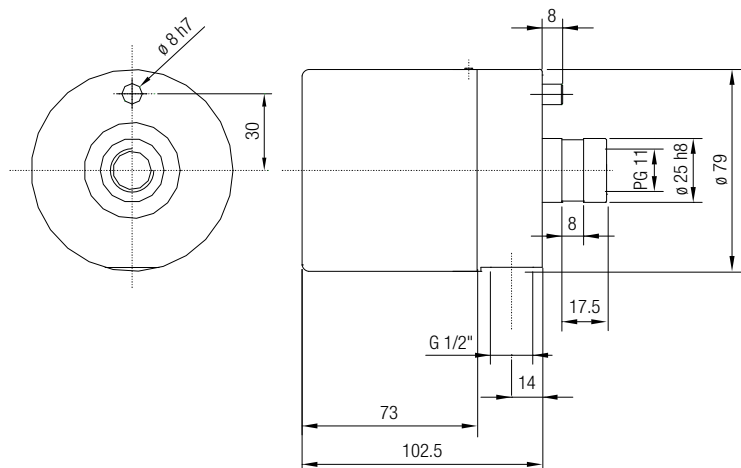

# Fixed Size Slip Rings

## CEE

CEE Series Slip Rings are produced in various sizes up to a maximum of 60 rings to meet the needs of each user.

CEE Slip Rings are suitable for the passage of signals or power up to a maximum current of 12 A. This series of slip rings features very small radial dimensions that allows them to fit in small spaces. This product is typically used on earthmoving machinery, usually in connection with fluidic rotary joints.

In fact, the reduced radial dimensions of the Slip Rings make it suitable for mounting inside the fluidic joint, greatly reducing overall height.



### General Characteristics

Size:	60 rings max.
Number of poles:	16 – 30 – 40 – 48 – 60
Pole function:	Low Power (up to 12 A), auxiliary, signals
Max. voltage:	230 V (AC)
Test voltage:	According to IEC 60947-1
Max. current:	12 A
Protection class:	IP54
Max. rotational speed:	50 rpm
Mounting position:	Vertical/horizontal
Working temp.:	+5 °C to +45 °C
Rotation sense:	Clockwise/counterclockwise

### Standard Construction

Body and cover material:	Anodized aluminum, external cover in PVC
Ring material:	Silver plated brass
Brush material:	Copper graphite (power) Silver alloy (signal)
Mechanical parts and screws:	Galvanized steel
Rotary shaft:	Ball bearing sealed and lubricated for life
Protection sheath:	Polypropylene
Cables:	2 m on both rings and brushes
Nameplate position:	On the cover

### Options

Special cables – Connectors – Special flange

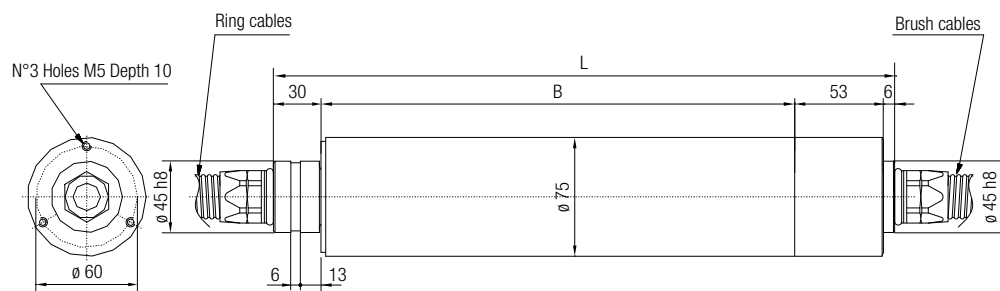

Size	No. of rings	Max. Current [A]	Max. Voltage [V]	Dimensions		Cables		
				B [mm]	L [mm]	Section	Insulating Material	Length [mm]
CEE 16	16	12	600	127	216	1.5 mm <sup>2</sup> 1.0 mm <sup>2</sup> or AWG 16 AWG 24	PVC or PETE	2
CEE 30	30			204	293			
CEE 40	40			259	348			
CEE 48	48			303	392			
CEE 60	60			369	458			

# ATEX Slip Rings

## ARIETE Ex d IIB T5 II 2G

ARIETE Series Slip Rings are suitable for use in potentially explosive atmospheres. It is important to verify that the slip ring is suitable for the area where it's operating, following the description on the label.

The essential requirements for safety in hazardous areas are established in European Directives 94/9/EC of March 23, 1994 (16/12/1999 1999/92/EC for plants).

Areas with a potentially explosive atmosphere are classified according to EN 60079-10, while the technical requirements of electrical equipment in classified areas are given in standard EN 60079-14. Technical protection for electrical appliances according to EN60079-0 and EN60079-1.

Based on these technical requirements and laws, the collector must be chosen taking into account the following factors:

- Type of plant surface facilities group II
- Category: 2G high-security, areas of use in zone 1 and zone 2 with the presence of flammable gases.
- Characteristics of flammable substances present in the form of gas, vapor, or mist.
- Subgroup: IIB (ethylene)
- Temperature Class: T5 (100 °C), defines the maximum surface temperature.

### General Characteristics

Number of Rings:	Max. 24 rings (12 A each)
Size:	Ariete 1A – Ariete 1B
Pole function:	Power up to 100 A, auxiliary, signals and data transmission
Max. voltage:	500 V (AC) – 220 V (DC)
Test voltage:	According to IEC 60947-1
Max. current:	100 A
ATEX code:	Ex d IIB T5 II 2G
Protection class:	IP65
Max. rotational speed:	30 rpm
Mounting position:	Vertical/horizontal
Working temp.:	-20 °C to +40 °C
Relative humidity:	30% to 60%
Rotation sense:	Clockwise/counterclockwise

### Standard Construction

Material:	Cast aluminum
Ring material:	Brass for power Gold plated or silver-plated brass for signals and data
Brush material:	Copper alloy brushes for power Silver alloy brushes for signal and data
Screws material:	Processed steel
Rotary shaft:	Ball bearings sealed and lubricated for life
Cables:	Special explosion-proof cables, 2 m connected to rings
Sheath:	Special for explosion-proof environment
Fittings material:	Special for explosion-proof environment
Nameplate:	According to ATEX standard, positioned on the cover

### Options

Heating elements:	15 W, 20 W, 30 W and 50 W Voltage 24 V (DC), 110/220/230 V (AC)
Cables:	Special on request

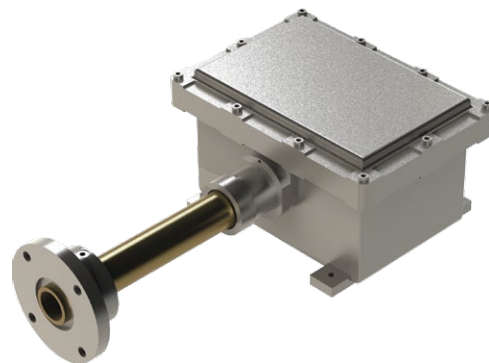
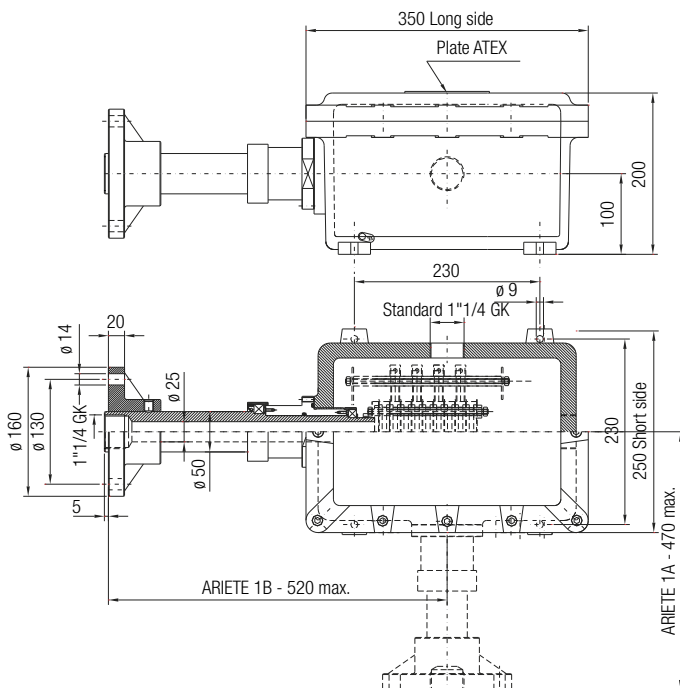

Size	Max. No. of rings on axis „A“			Max. No. of rings on axis „B“		Max. Voltage
	15 A or Signals	50 A	100 A	15 A or Signals	50 A	
ARIETE 1A	13	6	6			550 V (AC)
ARIETE 1B				24	12	220 V (DC)

# ATEX Slip Rings

## STAR 0, STAR 1, STAR 2, STAR 3 Ex d I I M2 ATEX

The STAR line is a low voltage series used in potentially explosive atmospheres. This product is mainly used on machines in yard environments and for labor in mines and tunnels. A STAR Slip Ring provides the user with a safe and high-level solution to meet their needs.

The essential requirements for safety in hazardous areas are established in European Directives 94/9/EC of March 23, 1994 (16/12/1999 1999/92/EC for plants). Areas with a potentially explosive atmosphere are classified according to EN 60079-10, while the technical requirements of electrical equipment in classified areas are given in standard EN 60079-14. Technical protection for electrical appliances according to EN60079-0 and EN60079-1.

It is important to verify that the slip ring meets all the characteristics and restrictions of the environment in which it is to be used.

The Slip Ring must be chosen considering the following factors:

- System type: group I mines
- Category: M2 elevated protection, not fed with presence of an explosive atmosphere
- Feature of the inflammable substances which are present as gas, steam, or fog
- Temperature class: 150 °C defines the maximum temperature of the surface

### General Characteristics

Type:	Modular
Size:	STAR 0, 1, 2, 3
Suitable for:	Analog to digital signals
Max. voltage:	1000 V (AC)
Test voltage:	According to IEC 60947-1
Max. current:	800 A continuous service
ATEX code:	Exd I I M 2
Protection class:	IP65
Max. rotational speed:	100 rpm
Mounting position:	Vertical/horizontal
Working temp.:	-20 °C to +40 °C
Relative humidity:	30% to 60%
Rotation sense:	Clockwise/counterclockwise

### Standard Construction

Slip ring body:	Painted steel
Ring material:	Bronze, brass, silver plated or gold plated
Brush material:	Power: graphite, high % copper Signals: Silver graphite
Screw material:	Processed steel
Rotary shaft:	Tight ball bearings, long life lubricated
Cables:	Special for explosion-proof environment, 2 m length
Sheath:	Special for explosion-proof environment
Nameplate:	Positioned on the cover

### Options

Heating elements:	15 W, 20 W, 30 W and 50 W Voltage 24 V (DC), 110/220/230 V (AC)
Cables:	Special on request

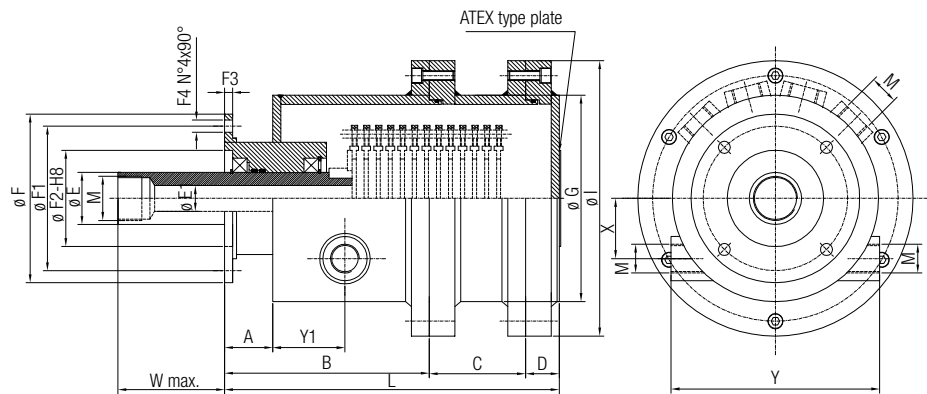

Collector type	A	B	C	D	E	E1	F	F1	F2	F3	F4	G	I	L	M	X	Y	Y1	W
STAR 0 - A	60	255	0	42	55 65	15 40	210	180	120	10	15	217	303	297	M36x1.5 M55x1.5	55	220	90	500
STAR 0 - B	60	255	120	42	55 65	15 40	210	180	120	10	15	217	303	417	M36x1.5 M55x1.5	55	220	90	500
STAR 0 - C	60	255	243	42	55 65	15 40	210	180	120	10	15	217	303	540	M36x1.5 M55x1.5	55	220	90	500
STAR 1 B.T.	65	205	263	47	75	54	240	200	130	20	17	508	600	515	M65x1.5	160	460	65	500
STAR 2 B.T.	65	245	273	47	100	68	300	250	180	20	17	660	750	565	M80x2	210	600	85	600
STAR 3 B.T.	78	258	273	47	120	92	350	300	200	20	17	660	750	578	M100x2	225	600	85	700
STAR 2 M.T. 6 kV	65	245	623	41	100	68	300	250	180	20	17	730	820	909	M80x2	210	670	85	600
STAR 2 M.T. 10 kV	65	245	773	41	100	68	300	250	180	20	17	830	920	1059	M80x2	210	770	85	600
STAR 3 M.T. 6 kV	78	258	623	41	120	92	350	300	200	20	17	730	820	922	M100x2	225	670	85	700
STAR 3 M.T. 10 kV	78	258	773	41	120	92	350	300	200	20	17	830	920	1072	M100x2	260	770	85	700

# ATEX Slip Rings

## SXD SERIES – ATEX – II 2D Ex tD A21 IP65 T 80 °C

SXD Series Slip Rings are used in potentially explosive atmospheres.

Always check to make sure that the slip ring is suitable to the classification area and to the features of the system in which it is installed.

The essential safety requirements to avoid explosion risks in the classified areas concerning equipment installations are stated by the European Norms 94/9/CE of 23rd March 1994. (1999/92/CE of 16/12/1999 for the system).

The areas exposed to explosive risks are classified according to the EN 61241-0 norm, while the technical requirements of the electrical systems in the classified areas are given by EN 61241/0-61241/1 norm.

According to these technical and legislative requirements, slip rings must be chosen by considering the following factors:

- System type: group II surface system
- Category: 2D elevate protection, zone 21 and zone 22 use areas with presence of inflammable dusts.
- Features of the inflammable substances which are present as coat and/or cloud.
- Temperature class: T 80 °C defines the maximum temperature of the surface.

### General Characteristics

Type:	Modular
Version:	Blind (C) and Through bore (P)
Poles function:	Power up to 40 A, auxiliary, signals and data transmission
Max. voltage:	690 V (AC)
Test voltage:	According to IEC 60947-1
Max. current:	40 A
Protection class:	IP65
Max. rotational speed:	150 rpm
Mounting position:	Vertical/horizontal
Working temp.:	-20 °C to +40 °C
Rotation sense:	Clockwise/counterclockwise

### Standard Construction

Material:	Anti-corrosive aluminum
Ring material:	Brass for power Silver plated or gold plated brass for signals and data
Brush material:	Copper graphite high % copper for power Silver graphite high % silver
Screw material:	Galvanized steel
Rotary shaft:	Ball bearings sealed and lubricated for life
Cables:	2 m length standard
Protection sheath:	2 m length standard
Nameplate position:	On the slip ring core

### Options

Cable glands and cabling on brushes:	Single core shielded, lengths by request
Cable on rings:	Length different from standard construction length (2 m)
Fixing accessories:	For rotor and stator
Terminal board:	For ring cabling
Heating elements:	15 W, 20 W, 30 W and 50 W Voltage 24V (DC), 110/220/230 V (AC)
Cables:	Special cables or customer cables on request
Connectors:	Cables with connectors or connectors on the body of the Slip Ring on both ring and brush sides
Encoder:	Fixing interfaces or complete solution following customer specification
Fluidic Joints:	Applicable with special construction
Fiber Optic	
Rotary Joints:	Applicable with special construction

Size	A	B	C	M	ø d	ø D	i	ø P	ø UA	ø US	ø F	ø O
SXD 50/P	236	64	29	66	20	150	100	2x8	4x13	4x13	120	N°4 ø9
SXD 70/P	335	62	23.5	82	34	200	140	2x10	4x13	4x13	145	N°4 ø9
SXD 91/P	424	60	23	92	44	254	190	2x12	4x15.8	4x15.8	160	N°4 ø9

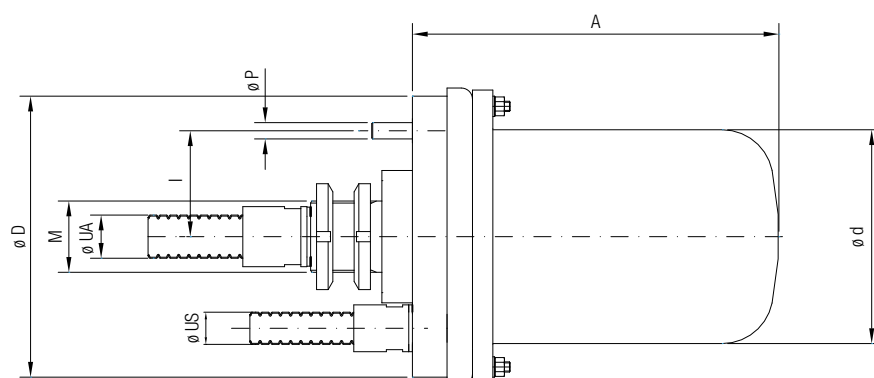

# Slip Rings for Data Transmission

## ETH/F-ETH/G

The ETH series is a new family of slip rings, specifically designed to work with real time Ethernet at 1000 Mbps. The slip rings have been designed and tested to guarantee a 100 Mbps transmission up to 60 m.

Measures were taken in the design of these slip rings to avoid problems related to magnetism and other typical slip ring disturbances. This removes potential problems for users and instead lets them focus on providing the best possible products in the most efficient manner.

Conductix-Wampfler provides a maintenance-free solution based on gold-on-gold technology and contact redundancy to guarantee uninterrupted data transmission. ETH/F Slip Rings are only recommended for applications with limited numbers of revolutions per day, with low rpm and no vibrations such as revolving stages or cable reels. It is likely that most industries will adopt ethernet-based solutions in the near future as has previously occurred for Profibus, so products such as these will be in high demand.

### General Characteristics

Type:	ETH/F, ETH/G
Number of Ethernet lines:	1 line at 100 Mbps or 1000 Mbps
Protection class:	IP65
Max. rotational speed:	30 RPM
Mounting position:	Vertical/horizontal
Working temp.:	+5 °C to +45 °C
Relative humidity:	90% without condensation
Rotation sense:	Clockwise/counterclockwise

### Standard Construction

Material:	Polyamide 66/color black
Ring material:	Gold plated brass
Brush material:	Quality alloy wire
Screw material:	Galvanized steel
Nameplate:	Positioned on the slip ring body

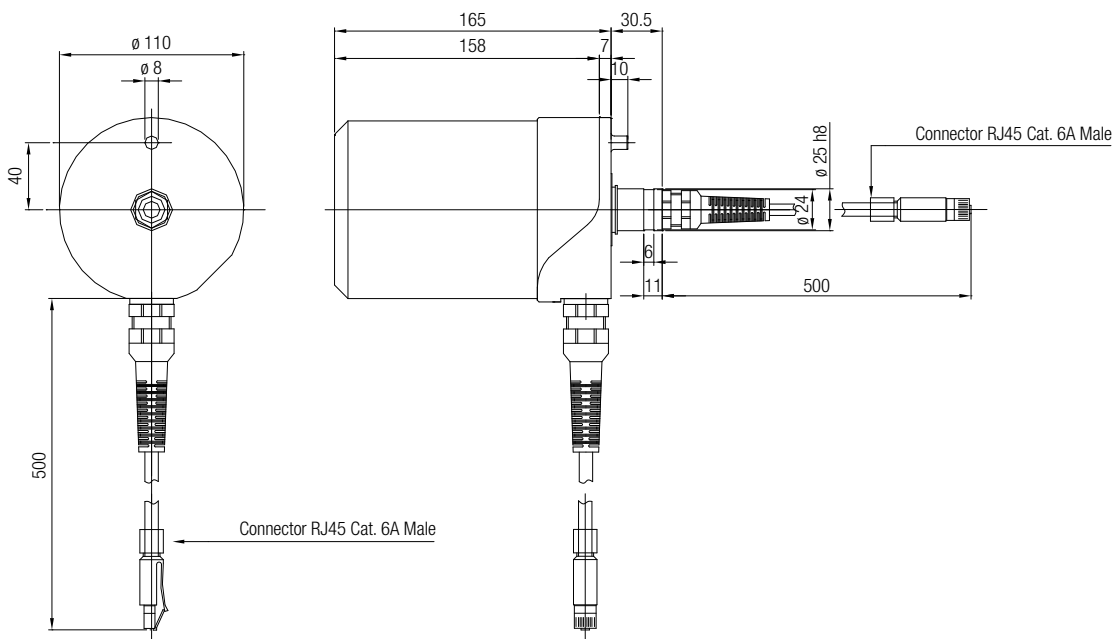

# Slip Rings for Data Transmission

## IndEth 100/IndEth 1000

The IndEth series is a family of Slip Rings which has been recently added to the Conductix-Wampfler product line and is properly designed to work with real time Ethernet at 1000 Mbps. A patent pending solution guarantees optimal performances with up to 50 m of cable. Lengths up to 80 m can be achieved with INDETH100E and INDETH1000E special Slip Rings – please contact us for further information.

This series has been properly designed to avoid problems related to magnetism or other typical slip rings disturbances and due to contact redundancy, the reliability is guaranteed.

Conductix-Wampfler provides a maintenance-free solution, based on gold-on-gold technology, which will keep machines functioning at peak performance.

IndEth technology is mainly applied in high-tech level markets such as the military and medical industries, but can be used in countless other industries.

IndEth100 is available with 1 or 2 Ethernet lines at 4 wires in the same mechanical case with IP65 protection class.

### General Characteristics

Type:	IndEth 100, IndEth 1000
Number of Ethernet lines:	1 or 2 lines at 100 Mbps; 1 line at 1000 Mbps
Protection class:	IP65
Max. rotational speed:	100 rpm
Mounting position:	Vertical/horizontal
PoE application:	Conductix-Wampfler to be consulted
Working temp.:	+5 °C to +45 °C
Relative humidity:	90% without condensation
Rotation sense:	Clockwise/counterclockwise

### Standard Construction

Material:	Steel/Aluminum
Ring material:	Gold-plated brass
Brush material:	Quality alloy wire
Screw material:	Galvanized steel
Nameplate:	Positioned on the slip ring body

### Options

Mounting Flange	
-----------------	--

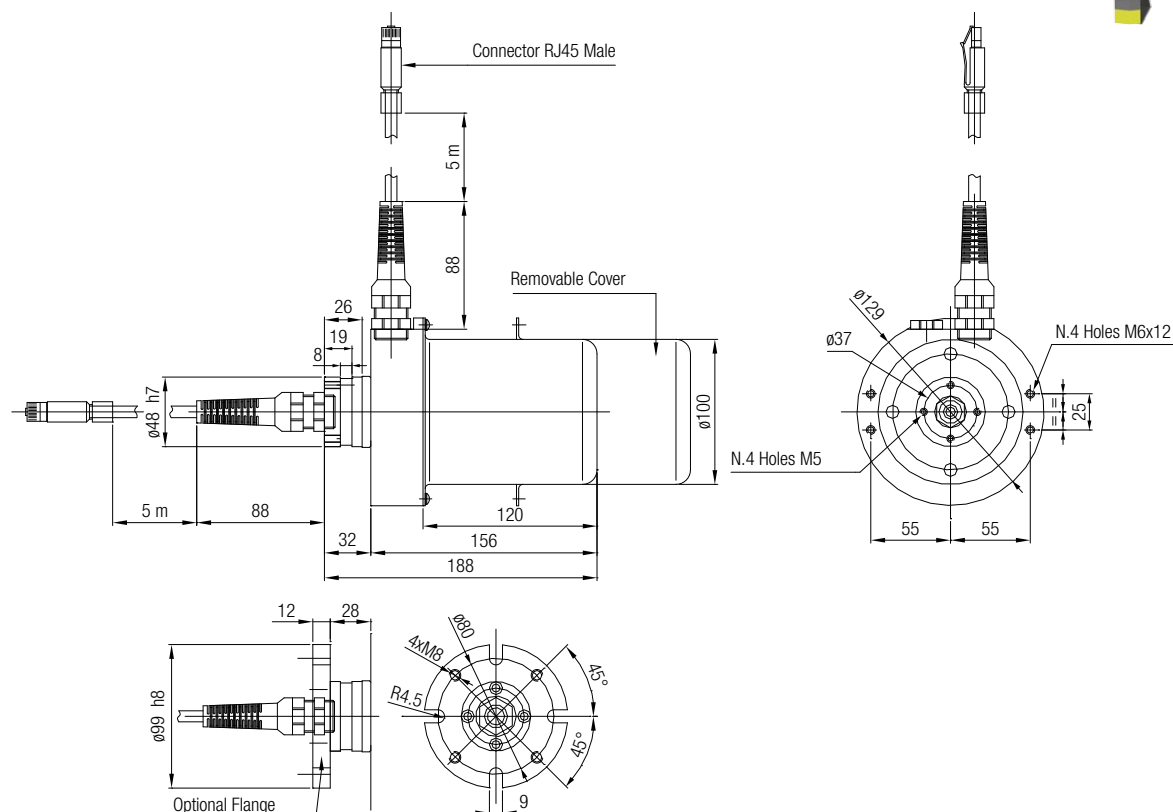

# Single Channel Fiber Optic Rotary Joints (FORJ)

## CFO 1 / CFO 1-TB / CFO 1-TBF

The Conductix-Wampfler FORJ type CFO 1 provides light transmission over rotating joints in all industrial automation applications, including machine tools, automated packaging, rotary stages, wind turbines, offshore rigs, material handling, etc.

Its very small dimensions make it suitable for integration in compact slip rings and applications where space is limited.

### General Characteristics (CFO 1)

No. of passive optical channels:	1
Fiber type:	Plastic Optical Fiber (POF)
Fiber core/cladding diameter:	980/1000 µm
Fiber bandwidth:	30 MHz * 100 m
Fiber attenuation @ 650 nm:	150 dB / km
Fiber numerical aperture:	0.46
External sheath of the optical cable:	PUR, orange, D = 4 mm
Standard length of the optical cables:	2 × (0.5 + 0.5) m
Connectors:	F-SMA (IEC 61754-22)
Weight:	90 g
Housing:	L 40 mm × Dia 20 mm
Housing material – Standard/Offshore:	303 Grade / 316 Grade Stainless Steel

### Optical Characteristics (CFO 1)

Max. attenuation @ 650 nm (red light), connectors and POF excluded,

variations included:	< 3 dB
Attenuation variation (@ 650 nm):	0.5 dB

### Mechanical Characteristics (CFO 1)

Max. rotating speed:	300 rpm
Lifetime (min.):	> 15 million cycles
Max. tension on optical cables:	70 N
Bending radius of the optical cable:	> 40 mm
Start up torque:	0.03 Nm
Vibration test:	EN 60068-2-64 (5-300 Hz random/10 g)
Structural shock test:	EN 60068-2-27; MIL-STD-810F; (semisinus 200 g / 6 ms)

### Environmental Characteristics (CFO 1)

Operating temperature:	-25 °C to +70 °C
Storage temperature:	-40 °C to +85 °C
Degree of protection:	IP65

### General Characteristics (CFO 1-TB / CFO 1-TBF)

No. of passive optical channels:	1
Fiber type:	Plastic Optical Fiber (POF)
Connectors:	F-SMA (IEC 61754-22)
Weight:	20 g (CFO 1-TB) / 30 g (CFO 1-TBF)
Housing material:	303 Grade Stainless Steel

### Optical Characteristics (CFO 1-TB / CFO 1-TBF)

Max. attenuation @ 650 nm (red light), variations included:	< 3 dB
Attenuation variation (@ 650 nm):	≤ 0.5 dB

### Mechanical Characteristics (CFO 1-TB / CFO 1-TBF)

Max. rotating speed:	300 rpm
Lifetime (min.):	> 15 million cycles

### Environmental Characteristics (CFO 1-TB / CFO 1-TBF)

Operating temperature:	-25 °C to +70 °C
Storage temperature:	-40 °C to +85 °C

CFO 1

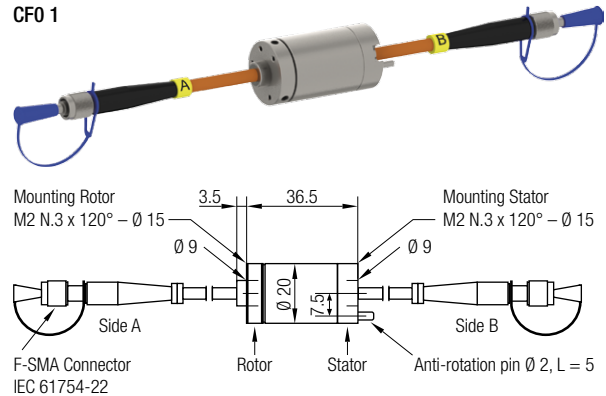

CFO 1-TB

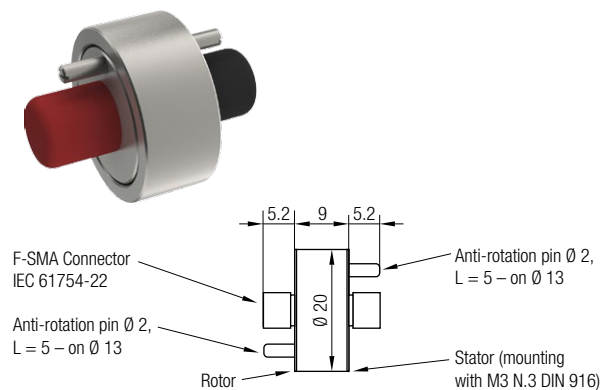

CFO 1-TBF

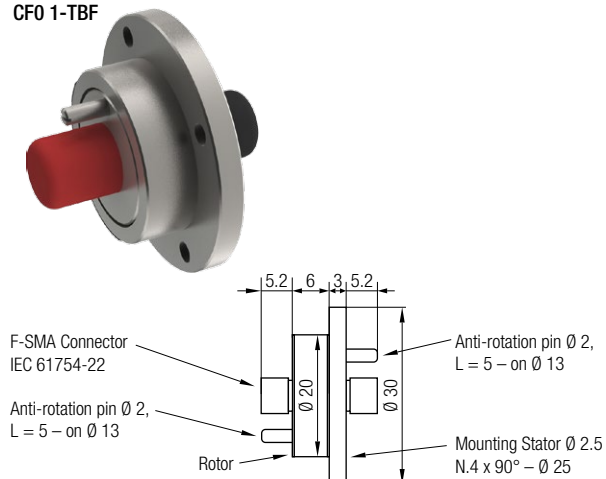



# Dual Channel Fiber Optic Rotary Joints (FORJ)

## CFO 2

The Conductix-Wampfler FORJ type CFO 2 provides true dual channel data transmission over rotating joints in all industrial automation applications, including machine tools, automated packaging, rotary stages, wind turbines, offshore rigs, materials handling, etc.

It is ruggedly constructed from stainless steel, with F-SMA connectors and a polyurethane (PUR) protective sheath, making it ideal for extreme environmental conditions. Excellent optical performance for blue 470 nm, green 525 nm and red 650/660 nm wavelengths with low channel crosstalk and high channel isolation.

Pre-installed optical cable with connectors – up to 50 m total length. Also available as a package with our CFC media converters (see datasheet CFC) for industrial real time Fast Ethernet (100 Mbps) transmission. Also compatible with industry standard media converters (e.g. Profibus).

### General Characteristics

No. of passive optical channels:	2
Fiber type:	Plastic Optical Fiber (POF)
Fiber core/cladding diameter:	980/1000 $\mu$ m
Fiber bandwidth:	30 MHz * 100 m
Fiber attenuation @ 650 nm:	150 dB / km
Fiber numerical aperture:	0.46
External sheath of the optical cable:	PUR, orange, D = 4 mm
Standard length of the optical cables:	2 x (0.5 + 0.5) m
Connectors:	F-SMA (IEC 61754-22)
Weight:	800 g
Housing:	L 105 mm x Dia 40 mm
Housing material – Standard/Offshore:	303 Grade / 316 Grade Stainless Steel

### Optical Characteristics

Max. attenuation Ch1 @ 650 nm, connectors and POF excluded, variations included:	10 dB
Max. attenuation Ch2 @ 650 nm, connectors and POF excluded, variations included:	6 dB
Attenuation variation Ch1 (@ 650 nm):	1.5 dB
Attenuation variation Ch2 (@ 650 nm):	2.5 dB
Cross talk:	> 30 dB
Insulation:	> 30 dB
Bandwidth @ -3dB: CFO2/00/00 (decreases with the POF length):	> 600 MHz (Gigabit Ethernet Ready)

### Mechanical Characteristics

Max. rotating speed:	300 rpm
Lifetime (min.):	> 15 million cycles
Max. tension on optical cables:	80 N
Bending radius of the optical cable:	> 40 mm
Start up torque:	0.1 Nm
Vibration test:	EN 60068-2-64 (5-300 Hz random/10 g)
Structural shock test:	EN 60068-2-27; MIL-STD-810F; (semisinus 200 g / 6 ms)

### Environmental Characteristics

Operating temperature:	-25 °C to +70 °C
Storage temperature:	-40 °C to +85 °C
Degree of protection:	IP65

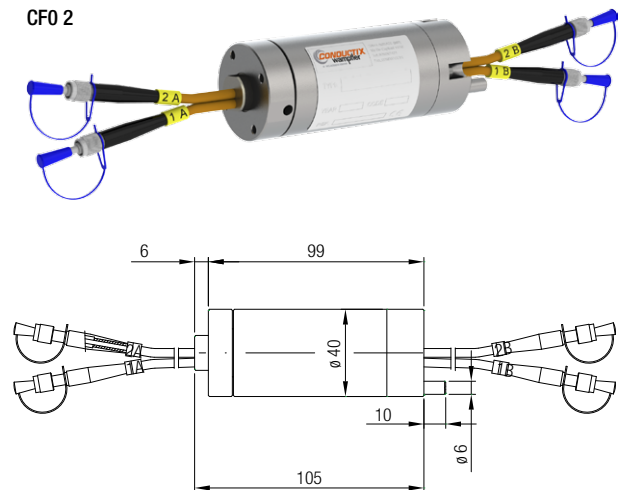

# Custom-built Slip Rings

## Power and Data Transmission

### Description AE000250

Application:	Electric Slip Ring for machine tool (5-axis)
Version:	Through-bore 205 mm
Use:	Power: Servo motor and auxilliary Signals and Data: Encoder, thermo couples and accelerometer
Sliding contact:	Gold alloy wires in sliding contact with gold-plated rings
Protection class:	IP54
Max. rotational speed:	30 rpm
Rotation type:	Intermittent
Mounting position:	Horizontal
Material:	Steel
Cables:	Pre-wired with connectors



### Description AE000294

Application:	Theater rotary stage
Version:	Blind; no through-bore
Use:	Power: Lights and stage control elements Signals and Data: Audio lines, DMX, Profibus, Analog video, Ethernet, FORJ (Fiber Optic Rotary Joint)
Sliding contact:	Gold-on-gold technology for data and signals Carbon based brushes on brass rings
Protection class:	IP55
Max. rotational speed:	30 rpm
Rotation type:	Discontinuous
Mounting position:	Vertical
Material:	Aluminum
Cables:	Pre-wired with connectors

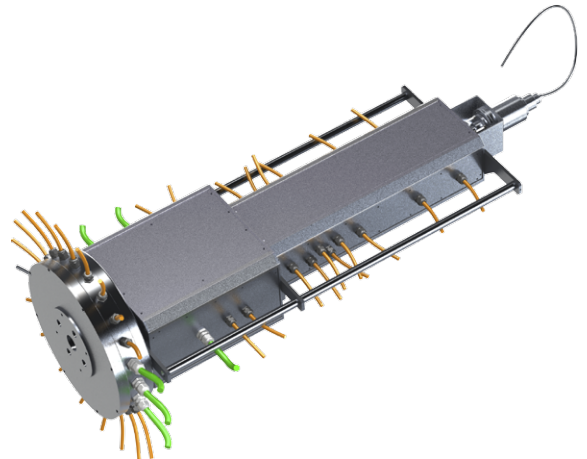

### Description AE000299

Application:	Electrocoating plant, zinc coating
Version:	Through-bore 160 mm
Use:	Power: 1 pole for DC current at 800 A
Sliding contact:	Copper brushes sliding on brass rings
Protection class:	IP67
Max. rotational speed:	10 rpm
Rotation type:	Discontinuous
Mounting position:	Horizontal
Material:	Nickel plated bronze
Cables:	Terminal boards on rings and brushes

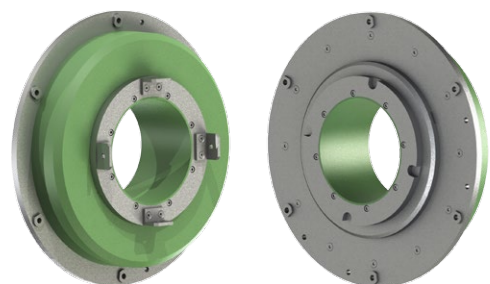

### Description AE000388

Application:	Tower crane
Version:	Blind; no through-bore
Use:	Power up to 500 A and auxilliary
Sliding contact:	Carbon based brushes sliding on brass/bronze rings
Protection class:	IP55
Max. rotational speed:	30 rpm
Rotation type:	Discontinuous
Mounting position:	Vertical
Material:	Painted steel
Cables:	Terminal board on rings and brushes

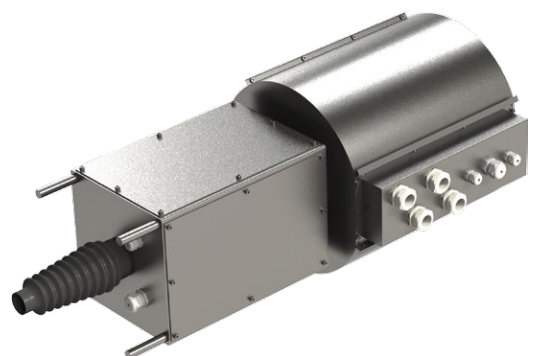

# Custom-built Slip Rings

---

## Power and Data Transmission

---

### Description AE000430B

Application:	Electric slip ring for special transfer machine
Version:	Blind; no through-bore
Use:	Power: 4 motors Signals and Data: 2 line DriveCliq with its feeding system
EMC:	2 separate parts for power and data (signals), with cable segregation
Sliding contact:	Power: Electrographite brushes with high percentage of copper Signals and Data: Redundant gold-on-gold contact
Protection class:	IP67
Max. rotational speed:	25 rpm
Rotation type:	Intermittent
Mounting position:	Vertical
Material:	Aluminum
Cables:	Pre-wired with pannels connectors on brushes and rings

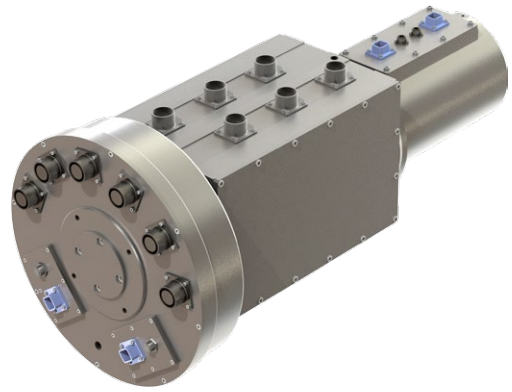

### Description AE080011A

Application:	Horizontal positioner for welding robots
Version:	Blind; no through-bore
Use:	Power: 2 lines at 24 V Signals and Data: PROFINET, Real Time 100 Mbps Fluid: Air passage
Sliding contact:	Gold alloy wires in sliding contact with gold plated rings
Protection class:	IP54
Max. rotational speed:	30 rpm
Rotation type:	Intermittent
Mounting position:	Horizontal
Material:	Steel
Cables:	Panel connectors on the brushed side, pre-wired with connectors on rings side



### Description

Application:	Pitch Control Slip Ring for Wind Turbines
Version:	Blind; no through-bore
Use:	Power: for blades pitch control, auxiliary Signal and data: Ethernet @100 Mbps
Sliding contact:	Gold alloy wires in sliding contact with gold-plated rings
Protection class:	IP54
Max. rotational speed:	50 rpm
Rotation type:	Continuous
Mounting position:	Horizontal
Material:	Cast aluminum and steel
Cables:	Panel connectors on both sides





EMERGENZA

ESTINTORE

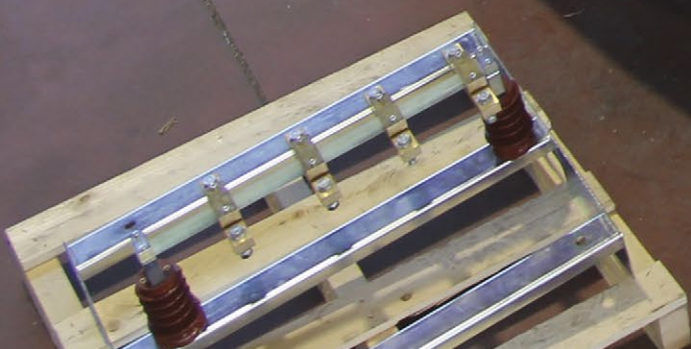

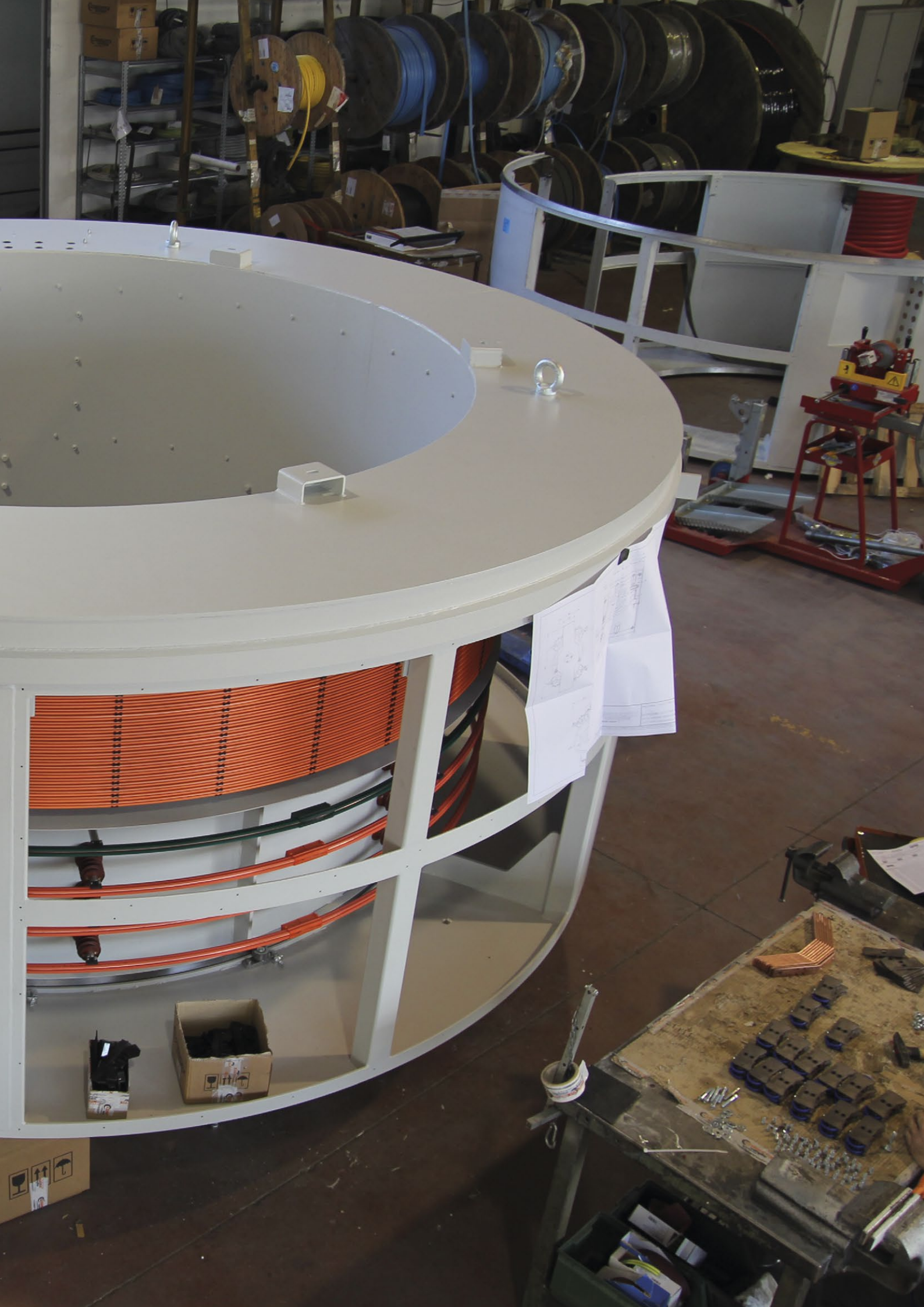

# Questionnaire | Specification Data

## Slip Ring Assemblies

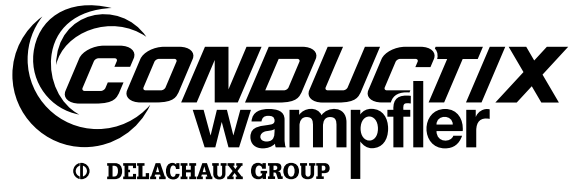

### Construction of the Slip Ring Assembly power section

Number of poles	Amperages [A]	Voltage [V]	Frequency [Hz]
+ PE			
+ PE			
+ PE			
+ PE			

### Data transmission or low voltage (up to 50 V)

• PE:  yes  no

Number of insulated shields/poles	Analog	Digital	Data transfer rate [kBit/s]	Transmission protocol e.g. Profibus, Fast-Ethernet

### Construction of the gas or fluid rotary joint

Number of channels	Nominal width [mm]	Pressure [bar]	Medium

### Application conditions

- Duty cycle: \_\_\_\_\_ [%]
- Rotational speed: \_\_\_\_\_ min<sup>-1</sup>
- Stationary operation:  yes  no  
(Stationary oper. = rotational speed < 1/min and more than 60% of the max. current load for more than 10 min)
- Mounting position:  vertical standing (standard)  
 vertical hanging  
 horizontal

### Environmental conditions

- Temperature: \_\_\_\_\_ °C up to \_\_\_\_\_ °C
- Dust: \_\_\_\_\_
- Humidity: \_\_\_\_\_ [%]
- Chemistry-Atmosphere: \_\_\_\_\_

### Construction

- Slip Ring Assembly:
- Slip Ring Assembly without housing IP00
  - Enclosed Slip Ring Assembly  
(Steel housing max. IP54, plastic housing max. IP65)
- Housing:
- Removable vertical-up
  - Divided for side (steel housing)
  - With side access window

- Wiring:
- Ring connection via terminal board
  - Pre-wiring  
Ring side \_\_\_\_\_ [m] from mounting flange  
Brush holder side \_\_\_\_\_ [m] from housing
  - Single strand  Cable \_\_\_\_\_

### Space requirements

- Max. free diameter: \_\_\_\_\_ [mm]
- Max. mounting height: \_\_\_\_\_ [mm]
- Required tube passage inside-ø: \_\_\_\_\_ [mm]

### Accessories

- End switch:  \_\_\_\_\_ [Number of]
- Heating:  24 V  110 V  230 V

### Application area of the slip ring assembly / rotary joint, special conditions, special accessories

---



---



---

### Customer Data

Company: \_\_\_\_\_ Customer-No.: \_\_\_\_\_

FAO: \_\_\_\_\_

Address: \_\_\_\_\_

\_\_\_\_\_

Phone: \_\_\_\_\_ Fax: \_\_\_\_\_

E-Mail: \_\_\_\_\_

# Your Applications – our Solutions

Slip Ring Assemblies from Conductix-Wampfler represent only one of the many solutions made possible by the broad spectrum of Conductix-Wampfler components for the transport of energy, data and fluid media. The solutions we deliver for your applications are based on your specific requirements. In many cases, a combination of several different Conductix-Wampfler systems can prove advantageous. You can count on all of Conductix-Wampfler’s Business Units for hands-on engineering support – coupled with the perfect solution to meet your energy management and control needs.



**Cable reels**  
Motorized reels and spring reels by Conductix-Wampfler hold their own wherever energy, data and media have to cover the most diverse distances within a short amount of time – in all directions, fast and safe.



**Festoon systems**  
It’s hard to imagine Conductix-Wampfler cable trolleys not being used in virtually every industrial application. They’re reliable and robust and available in an enormous variety of dimensions and designs.

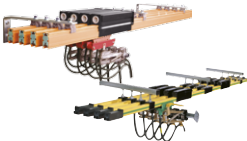

**Conductor rails**  
Whether they’re enclosed conductor rails or expandable single-pole systems, the proven conductor rails by Conductix-Wampfler reliably move people and material.



**Non-insulated conductor rails**  
Extremely robust, non-insulated conductor rails with copper heads or stainless steel surfaces provide the ideal basis for rough applications, for example in steel mills or shipyards.



**Energy guiding chains**  
The “Jack of all trades” when it comes to transferring energy, data, air, and fluid hoses. With their wide range, these energy guiding chains are the ideal solution for many industrial applications.



**Slip ring assemblies**  
Whenever things are really “moving in circles”, the proven slip ring assemblies by Conductix-Wampfler ensure the flawless transfer of energy and data. Here, everything revolves around flexibility and reliability!



**Inductive Power Transfer IPT®**  
The no-contact system for transferring energy and data. For all tasks that depend on high speeds and absolute resistance to wear.



**Reels, retractors and balancers**  
Whether for hoses or cables, as classical reels or high-precision positioning aids for tools, our range of reels and spring balancers take the load off your shoulders.



**Jib booms**  
Complete with tool transporters, reels, or an entire media supply system – here, safety and flexibility are key to the completion of difficult tasks.

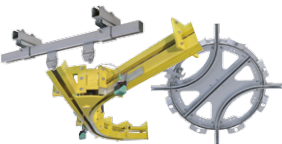

**Conveyor systems**  
Whether manual, semiautomatic or with Power & Free – flexibility is achieved with fully customized layouts and locations.

# www.conductix.com

---

## **Conductix-Wampfler**

has just one critical mission:

To provide you with energy and data transmission systems that will keep your operations up and running 24/7/365.

To contact your nearest sales office, please refer to:

[www.conductix.com/  
contact-search](http://www.conductix.com/contact-search)



Ⓧ DELACHAUX GROUP