

Festoon Systems for C-Rails

Program 0230



CONDUCTIX
wampfler
© DELACHAUX GROUP

Contents

System Arrangement Program 0230

Rails and Mounting Parts.....	5
Festoon Systems for Flat Cables.....	5
Festoon Systems for Round Cables.....	5

C-Rails and Accessories Program 0230

C-Rails.....	6
90°- Curves.....	6
Track Couplers.....	7
Track Couplers, Two-Piece.....	7
Track Support Brackets, Two-Piece.....	7
Track Support Bracket, One-Piece, for Ceiling Attachment.....	8
Track Support Bracket, One-Piece, with Square Nut for Attachment to Support Arms.....	8
Track Support Bracket, One-Piece, for Attachment to Existing Steel Structure.....	8
Track Support Brackets, Two-Piece, for Ceiling Attachment.....	8
Track Support Brackets, Three-Piece, for Ceiling Attachment.....	9
Track Support Brackets, Three-Piece, with Square Nut for Attachment to Support Arms.....	9
Track Support Brackets, Three-Piece, for Attachment to the Existing Steel Structure.....	9
Track Support Bracket for Attachment to the Existing Steel Structure.....	10
Track Support Bracket and Coupler, One-Piece, for Ceiling Attachment.....	10
Track Support Bracket and Coupler, One-Piece with Square Nut for Attachment to Support Arms.....	10
Track Support Bracket and Coupler, One-Piece for Attachment to the Existing Steel Structure.....	10
Track Support Brackets for Attachment to the Existing Steel Structure.....	11
Track Support Bracket, bare to weld on.....	12
Track Support Bracket and Coupler, bare to weld on.....	12
Track Support Bracket for Direct Attachment below I-Beams.....	12
Bolt complete.....	12
Support Arms 30x32x2 - punched.....	13
Support Arms 40x40x2.5 - punched.....	13
Support Arms 30x32x2 - unpunched.....	14
Support Arms 40x40x2.5 - unpunched.....	14
Permissible Load for Support Arms.....	14
Bracket for Support Arms 30x30x2 to be bolted with 2-Hole Connecting Plate.....	15
Bracket for Support Arms 40x40x2.5 to be bolted with 2-Hole Connecting Plate.....	15
Bracket for Support Arms 40x40x2.5 to be bolted with 4-Hole Connecting Plate.....	15
Console Brackets to be bolted with 4-Hole Connecting Plate.....	16
Brackets, bare to be welded.....	16
Girder Clips, Clamping Thickness 4 - 20 mm.....	17
Girder Clips, Clamping Thickness 18 - 36 mm.....	17
Girder Clips, Twist-Secured, Clamping Thickness 6 - 25 mm.....	17
Application Examples for Support Arm and C-Rail Fastening with Support Arms – unpunched.....	18
Application Examples for Support Arm and C-Rail Fastening with Support Arms – punched.....	18
Application Example for Support Arm and C-Rail Fastening with Welded Brackets.....	18
End Stop 30x24.....	19
End Stop with Rubber Buffer.....	19
End Stop without Rubber Buffer.....	19
Application Example for End Stop Assembly.....	19
Towing Arms.....	20
End Caps.....	20
Clips with or without Cable Tie.....	20

Cable Trolleys for Flat Cables Program 0230

Plastic Cable Trolleys.....	21
Steel Cable Trolleys with Plastic Cable Support.....	22
Steel Cable Trolleys, Light Series without Buffer.....	23
Steel Cable Trolleys, Light Series with Buffer.....	23
Steel Cable Trolleys, Heavy Series.....	24

Contents

Cable Trolleys for Round Cables Program 0230

Plastic Cable Trolleys with Ball Joint for Cable Clip 020131	25
Steel Cable Trolleys with Ball Joint for Cable Clips 020131 or 020431	25
Steel Cable Trolleys with Bracket for Cable Clips 020133	26
Cable Clips for Fixation at the Ball Joint	27
Cable Clips for Fixation at the Bracket	27
Hose Clip for Fixation at the Ball Joint	27
Hose Clip for Fixation at the Bracket	27
Steel Cable Trolleys, Heavy Series for Clamping of Round Cables with a max. Difference in Diameter of 6 mm	28
Steel Cable Trolleys, Heavy Series for Clamping of Round Cables with a max. Difference in Diameter of 16 mm	29

Cable Trolleys and Accessories for Traversing, Program 0230

Cable Trolleys for Flat Cables with Additional Rollers	30
Cable Trolleys for Round Cables with Additional Rollers	30
Transfer Guide for C-Rail 023200	31
Cable Trolleys with Horizontal Guide Rollers for Applications with Increased Horizontal Forces	31

Ideal Control Unit Trolleys Program 0230

Ideal Control Unit Trolleys with Plug and Socket Connection – Basic Configuration	32
Ideal Control Unit Trolleys with Plug and Socket Connection – Pre-Assembled	32
Ideal Control Unit Trolley with Plastic Terminal Box – Basic Configuration	33
Ideal Control Unit Trolleys with Plastic Terminal Box – Pre-Assembled	33
Ideal Control Unit Trolleys with Terminal Box of Steel – Basic Configuration	34
Control Trolley Upper Parts	34
Basic Ideal Control Unit Trolleys for Round Cables	35

Accessories for Festoon Systems Program 0230

Application Examples	36
Towing Ropes Pre-Assembled	37
Ropes	37
Spring Safety Hook	37
Rope Thimbles	37
Simplex Rope Clip	37
Rope Eyes	38
Cable Clamps	38
Brake Glider	38
Brake Trolley	38
Cable Trolley Upper Parts	39
Cable Support	39
Ball Joint	39
Brackets, complete	39
Plastic Trolleys 2 Rollers	40
Plastic Trolleys 4 Rollers	40
Steel Trolley 2 Rollers	40
Steel Trolley 4 Rollers without Buffer	40
Steel Trolley 4 Rollers with Buffer	41
S-Hook	41
Spring Safety Hook	41
Cable Collar, Plastic	41
Strap for Cable Bundle	42
Cable Clips with Bracket	42

Helpful Hints

Determination of the Load Capacity of C-Rails	43
Load Diagram for C-Rail 30x32x2 (023200 / 023400 / 023404)	43
Load Diagram for C-Rail 30x32x1.5 (023201)	44
Technical Data	45
Formulas to Determine the Number of Loops, Cable Length and Loop Depth	45
Definition of the cable arrangement and cable trolley selection	46
Cable Factors	46
Permissible Loads of the Rollers	46

System Arrangement Program 0230

Rails and Mounting Parts

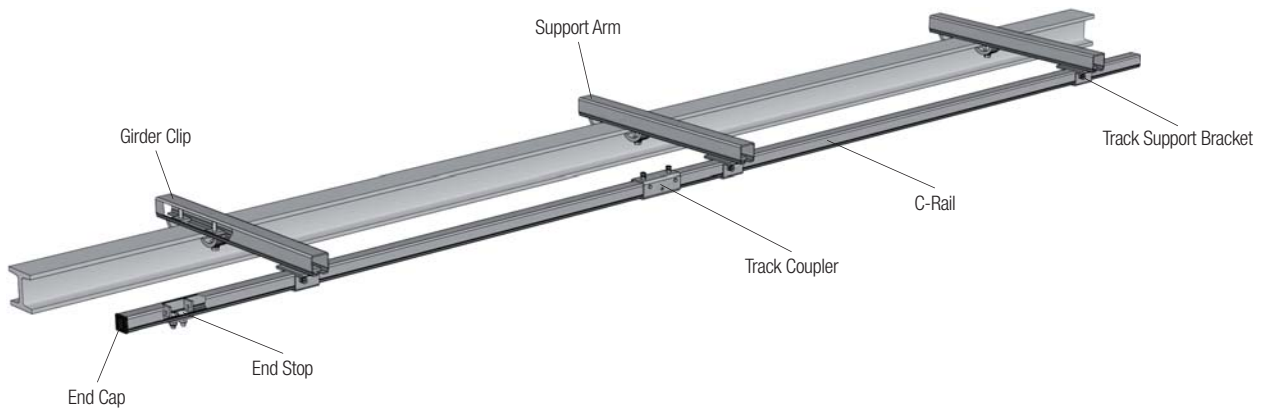

Festoon Systems for Flat Cables

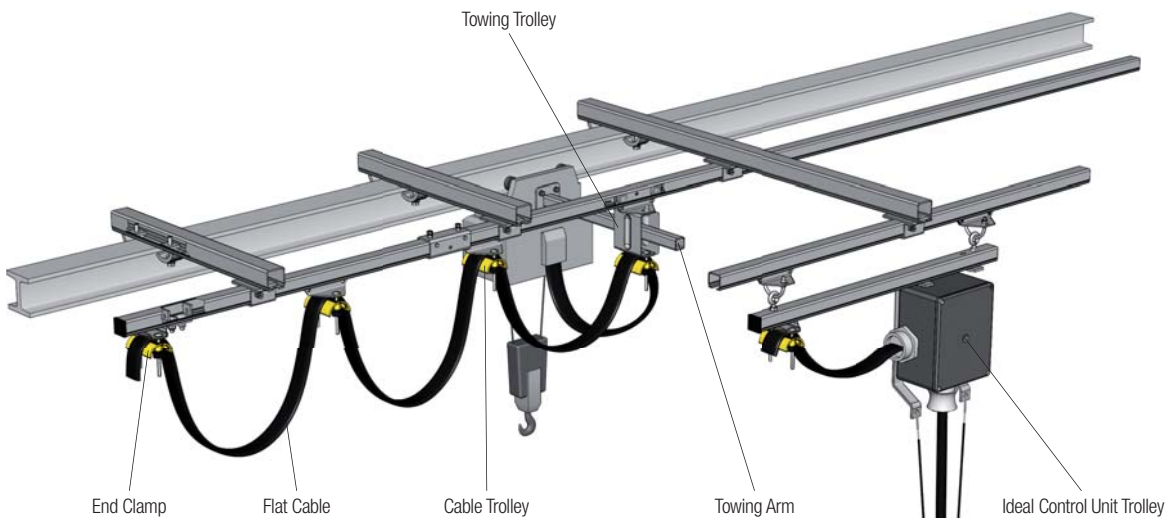

Festoon Systems for Round Cables

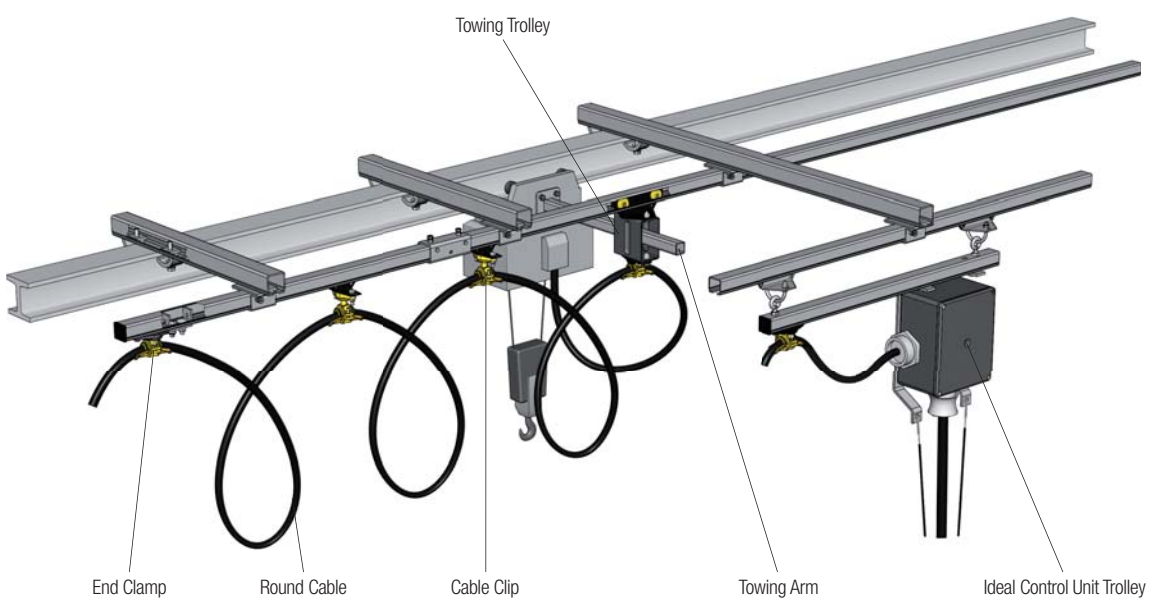

C-Rails and Accessories

Program 0230

C-Rails

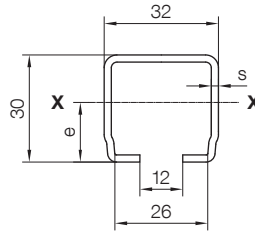

Order No.	Material	Length [mm]	Thickness s [mm]	I_x [cm ⁴]	Static Values		Weight [kg/m]			
					W_x [cm ³]	e [mm]				
023200-6	sendzimir galvanized steel	6000	2	2.42	1.45	16.70	1.56			
023200-4		4000								
023201-6		6000	1.5					1.10	17.10	1.17
023201-4		4000								
023400-6	stainless steel V4A 1.4571	6000	2	2.42	1.45	16.70	1.56			
023400-4		4000								

Other lengths or stainless steel V2A (1.4301) on request

90°- Curves

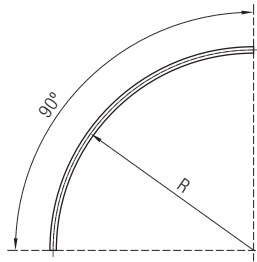

Order No.	Material	R [mm]	Developed Length [mm]	Loop Depth max. 0.35 x R [mm]	For Max. Trolley Length [mm]	Weight [kg]
023203-01200	1200	1885	420	160	2.9	
023203-01400	1400	2200	490	200	3.4	
023203-01600	1600	2510	560	200	3.9	
023203-01800	1800	2830	630	250	4.4	
023203-02000	2000	3140	700	250	4.9	
023403-01000	stainless steel V4A 1.4571	1000	1570	350	160	2.4
023403-01200		1200	1885	420	160	2.9
023403-01400		1400	2200	490	200	3.4
023403-01600		1600	2510	560	200	3.9
023403-01800		1800	2830	630	250	4.4
023403-02000		2000	3140	700	250	4.9

Other curves or stainless steel V2A (1.4301) on request

C-Rails and Accessories

Program 0230

Track Couplers

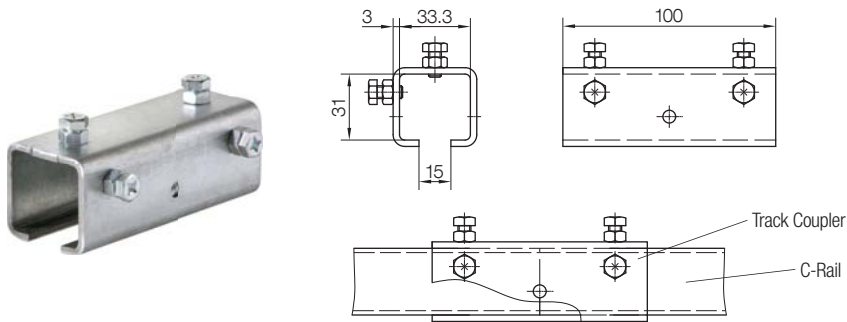

Order No.	Material	Weight [kg]
023210	galvanized steel	0.280
023410	stainless steel V4A	0.280

Note

A track coupler must be provided at each track joint.

Track Couplers, Two-Piece

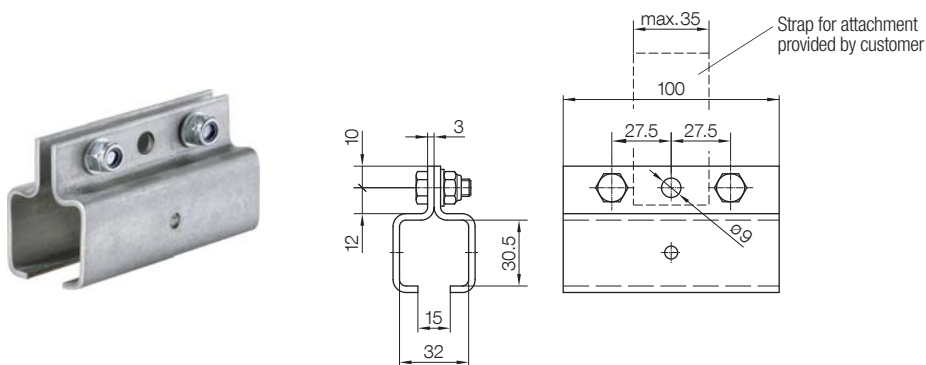

Order No.	Material	Perm. Load [kg]	Weight [kg]
023211	galvanized steel	100	0.480
023411	stainless steel V4A	100	0.480

Track Support Brackets, Two-Piece

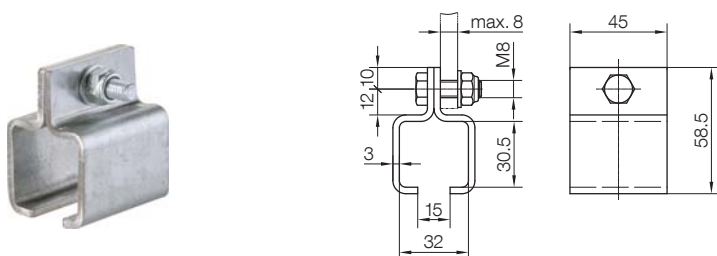

Order No.	Material	Perm. Load [kg]	Weight [kg]
023247	galvanized steel	100	0.200
023447	stainless steel V4A	100	0.200

Design in stainless steel V4A

C-Rails and Accessories

Program 0230

Track Support Bracket, One-Piece, for Ceiling Attachment

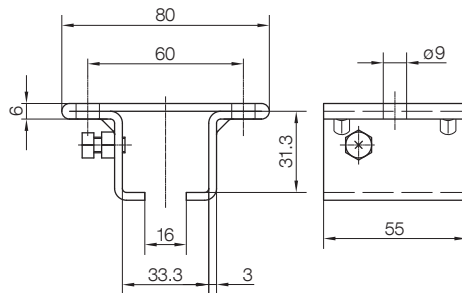

Order No. 023225

- Material: galvanized steel
- Perm. load: 160 kg
- Weight: 0.245 kg

Track Support Bracket, One-Piece, with Square Nut for Attachment to Support Arms

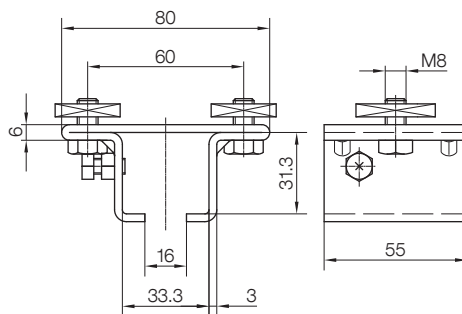

Order No. 023226

- Material: galvanized steel
- Perm. load: 160 kg
- Suitable for support arm type: 020185, 020186, 020275, 020276
- Weight: 0.320 kg

Track Support Bracket, One-Piece, for Attachment to Existing Steel Structure

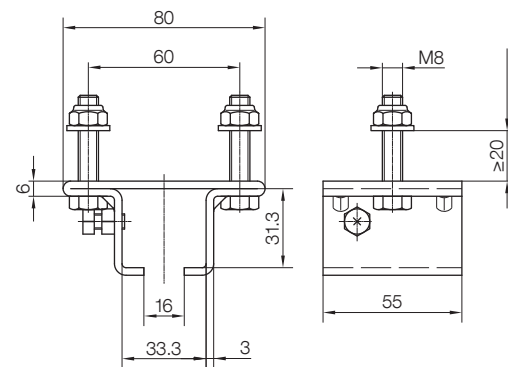

Order No. 023227

- Material: galvanized steel
- Perm. load: 160 kg
- Weight: 0.295 kg

Track Support Brackets, Two-Piece, for Ceiling Attachment

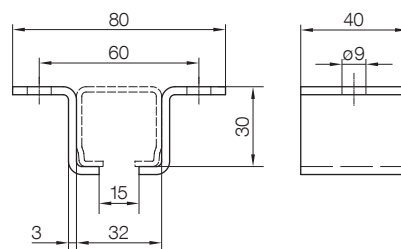

Order No.	Material	Perm. Load [kg]	Weight [kg]
023221	galvanized steel	63	0.100
023421	stainless steel V4A	63	0.100

C-Rails and Accessories

Program 0230

Track Support Brackets, Three-Piece, for Ceiling Attachment

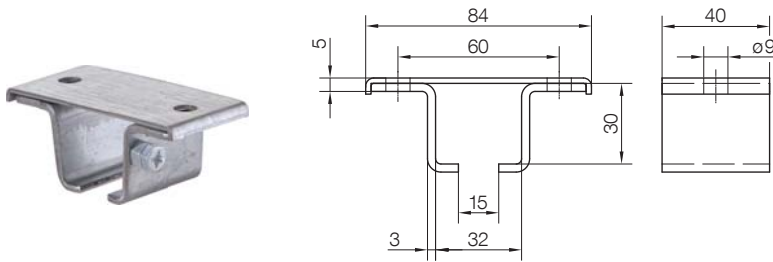

Order No.	Type	Material	Perm. Load [kg]	Weight [kg]
023220	without locking screw	galvanized steel	63	0.160
023220-1	with locking screw			0.170
023420	without locking screw	stainless steel V4A	63	0.160
023420-1	with locking screw			0.170

Track Support Brackets, Three-Piece, with Square Nut for Attachment to Support Arms

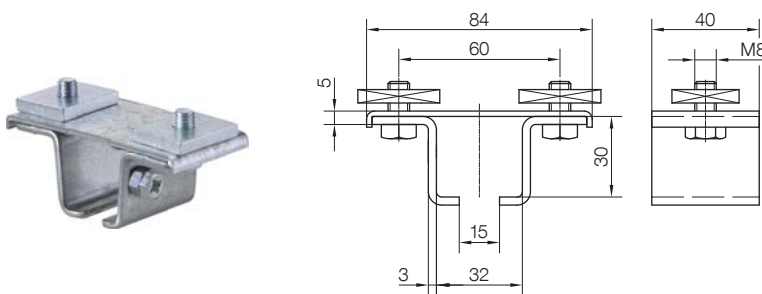

Order No.	Type	Material	Suitable for Support Arm Type	Perm. Load [kg]	Weight [kg]
023222	without locking screw	galvanized steel	020185. 020186 020275. 020276	63	0.235
023222-1	with locking screw				0.245
023422	without locking screw	stainless steel V4A	020485 020488	63	0.235
023422-1	with locking screw				0.245

Track Support Brackets, Three-Piece, for Attachment to the Existing Steel Structure

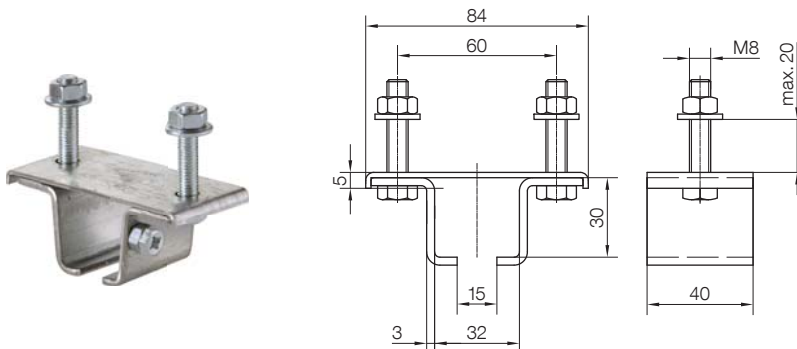

Order No.	Type	Material	Perm. Load [kg]	Weight [kg]
023223	without locking screw	galvanized steel	63	0.200
023223-1	with locking screw			0.210
023423	without locking screw	stainless steel V4A	63	0.200
023423-1	with locking screw			0.210

Design in stainless steel V4A

C-Rails and Accessories

Program 0230

Track Support Bracket for Attachment to the Existing Steel Structure

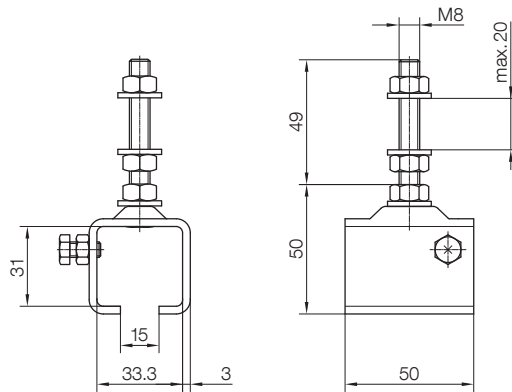

Order No. 023231

- Material: galvanized steel
- Perm. load: 63 kg
- Weight: 0.195 kg

Track Support Bracket and Coupler, One-Piece, for Ceiling Attachment

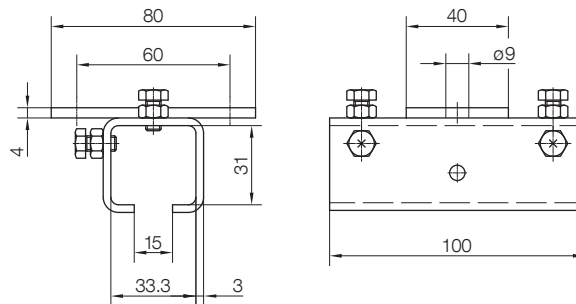

Order No. 023228

- Material: galvanized steel
- Perm. load: 160 kg
- Weight: 0.360 kg

Track Support Bracket and Coupler, One-Piece with Square Nut for Attachment to Support Arms

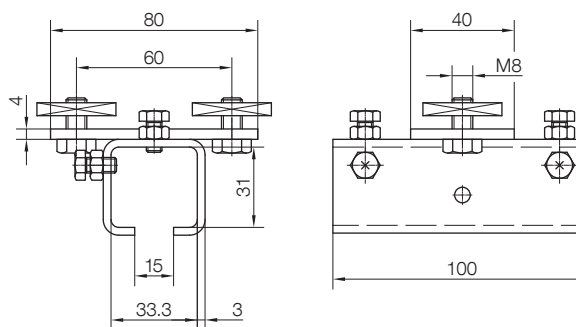

Order No. 023229

- Material: galvanized steel
- Perm. load: 160 kg
- Suitable for support arm type: 020185, 020186, 020275, 020276
- Weight: 0.435 kg

Track Support Bracket and Coupler, One-Piece for Attachment to the Existing Steel Structure

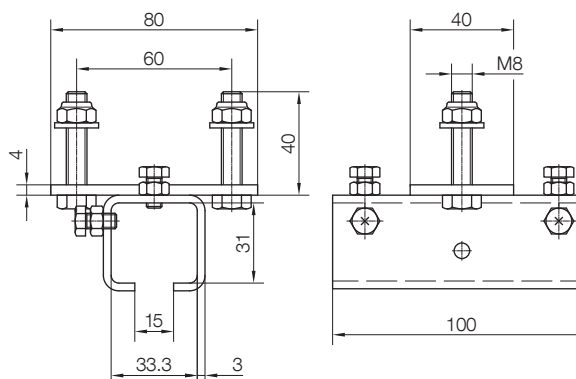

Order No. 023230

- Material: galvanized steel
- Perm. load: 160 kg
- Weight: 0.400 kg

C-Rails and Accessories

Program 0230

Track Support Brackets for Attachment to the Existing Steel Structure

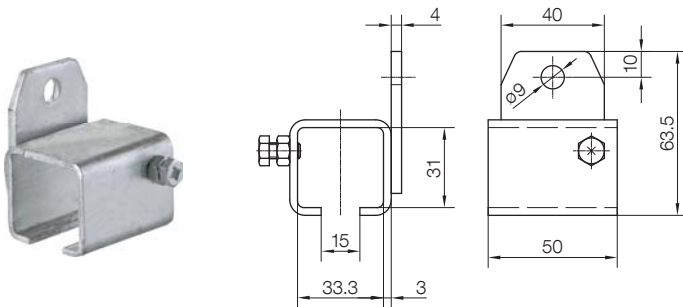

Order No.	Material	Perm. Load [kg]	Weight [kg]
023240	galvanized steel	100	0.200
023440	stainless steel V4A	100	0.200

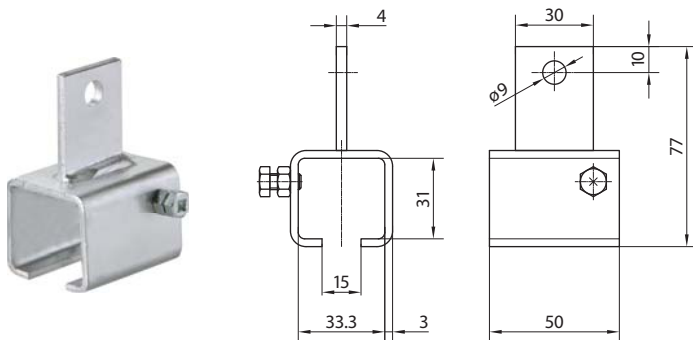

Order No.	Material	Perm. Load [kg]	Weight [kg]
023241	galvanized steel	100	0.175
023441	stainless steel V4A	100	0.175

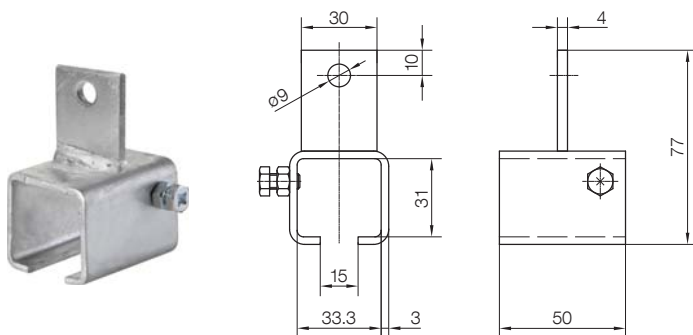

Order No.	Material	Perm. Load [kg]	Weight [kg]
023242	galvanized steel	100	0.175
023442	stainless steel V4A	100	0.175

C-Rails and Accessories

Program 0230

Track Support Bracket, bare to weld on

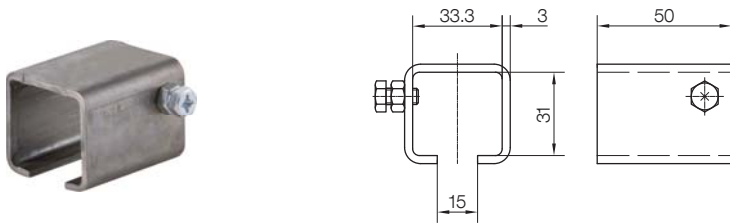

- Order No. 023224**
- Material: bare steel
 - Weight: 0.125 kg

Track Support Bracket and Coupler, bare to weld on

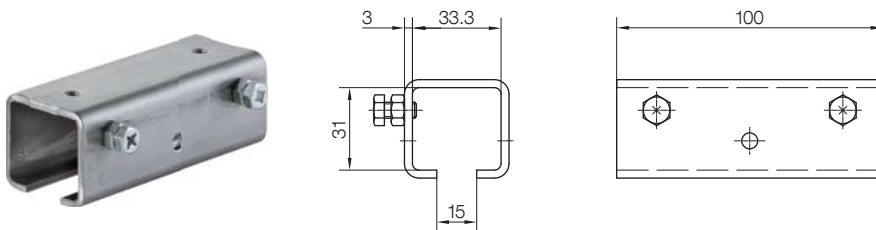

- Order No. 023232**
- Material: bare steel
 - Weight: 0.260 kg

Track Support Bracket for Direct Attachment below I-Beams

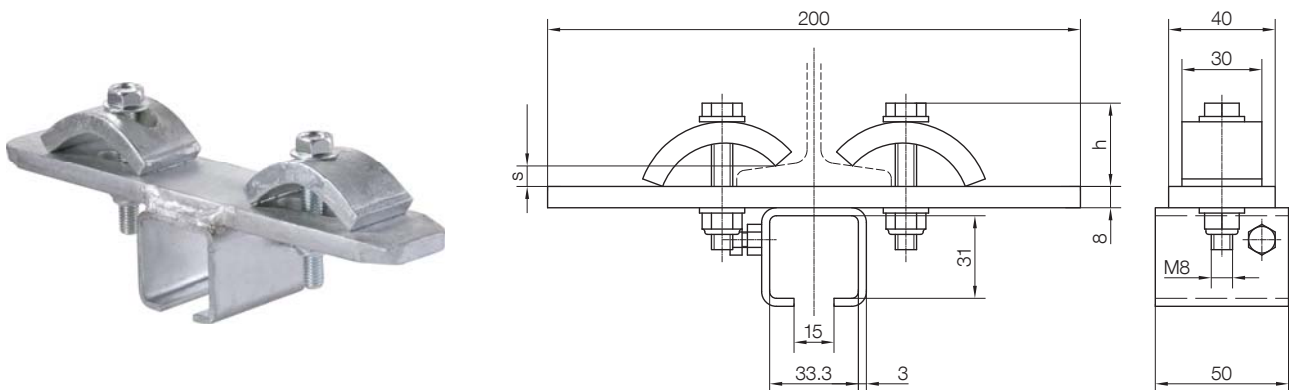

Order No.	Material	Suitable for I-Beam	Perm. Load [kg]	Weight [kg]
023236	galvanized steel	flange widths: 40 - 103 mm, flange thickness: 4 - 20 mm	100	0.700

Bolt complete

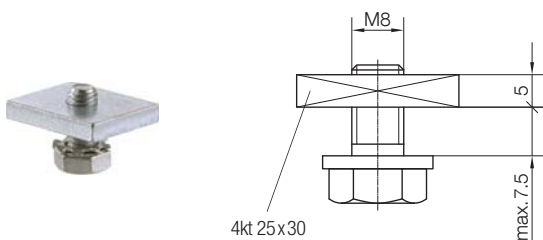

Order No.	Packing Unit	Material	Weight [kg]
020176-8x16P	20 pcs.	galvanized steel	0.045
020476-8x16P	20 pcs.	stainless steel V4A	0.045

C-Rails and Accessories

Program 0230

Support Arms 30x32x2 - punched

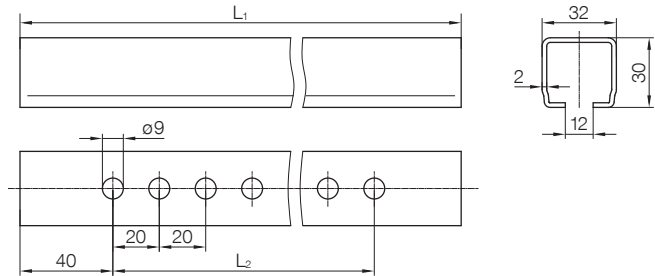

Order No.	L ₁ [mm]	L ₂ [mm]	Material	Weight [kg]
020185-0250	250	200	sendzimir galvanized steel	0.390
020185-0315	315	260		0.500
020185-0400	400	340		0.625
020185-0500	500	340		0.780
020185-0630	630	340		0.980
020185-0800	800	340		1.245
020185-1000	1000	340		1.550
020185-1250	1250	340		1.945
020485-0400	400	340	stainless steel V4A 1.4571	0.625
020485-0500	500	340		0.780
020485-0630	630	340		0.980
020485-0800	800	340		1.245
020485-1000	1000	340		1.550
020485-1250	1250	340		1.945

Support Arms 40x40x2.5 - punched

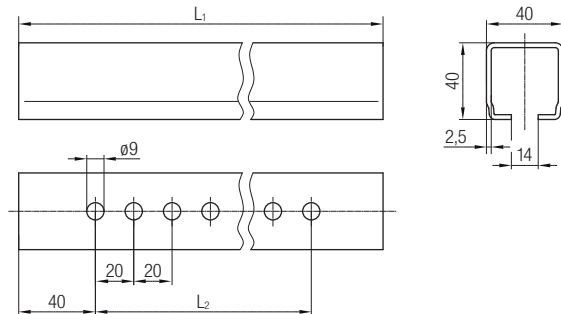

Order No.	L ₁ [mm]	L ₂ [mm]	Material	Weight [kg]
020186-0250	250	200	sendzimir galvanized steel	0.625
020186-0315	315	260		0.785
020186-0400	400	340		1.000
020186-0500	500	340		1.250
020186-0630	630	340		1.575
020186-0800	800	340		2.000
020186-1000	1000	340		2.500
020186-1250	1250	340		3.125
020488-0400	400	340	stainless steel V4A 1.4571	1.000
020488-0500	500	340		1.250
020488-0630	630	340		1.575
020488-0800	800	340		2.000
020488-1000	1000	340		2.500
020488-1250	1250	340		3.125

C-Rails and Accessories

Program 0230

Support Arms 30x32x2 - unpunched

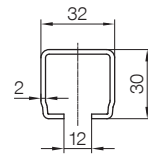
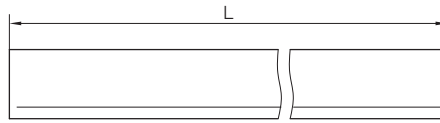

Order No.	L [mm]	Material	Weight [kg]
020275-0250	250	sendzimir galvanized steel	0.390
020275-0400	400		0.625
020275-0500	500		0.780
020275-0630	630		0.980
020275-0800	800		1.245
020275-1000	1000		1.560
020275-1250	1250		1.945
020275-1500	1500		1.795
020275-2000	2000		3.120

Support Arms 40x40x2.5 - unpunched

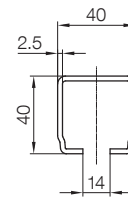
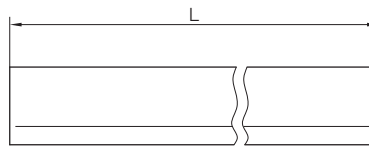

Order No.	L [mm]	Material	Weight [kg]
020276-0315	315	sendzimir galvanized steel	0.785
020276-0450	450		1.125
020276-0650	650		1.625
020276-0950	950		2.375
020276-1150	1150		2.875
020276-1340	1340		3.350
020276-1520	1520		3.800
020276-1800	1800		4.500
020276-2000	2000		5.000

Permissible Load for Support Arms

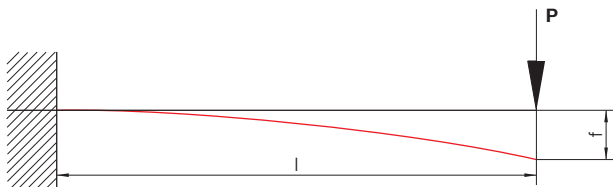

Notes

- calculated with $\sigma = 140 \text{ N/mm}^2$ tension
- f = appropriate max. resulting deflection

		l [m]								
		0.25	0.40	0.50	0.65	0.80	1.00	1.25	1.52	2.00
Support Arm 30x30x2	P [kg]	76.0	47.5	38.0	29.0	24.0	19.0	15.0	12.5	9.50
	f [cm]	0.08	0.20	0.32	0.60	0.90	1.40	2.20	3.30	5.70
Support Arm 40x40x2.5	P [kg]	164.5	103.0	82.0	63.0	51.5	41.0	33.0	27.0	20.5
	f [cm]	0.07	0.20	0.30	0.45	0.70	1.10	1.70	2.50	4.30

C-Rails and Accessories

Program 0230

Bracket for Support Arms 30x30x2 to be bolted with 2-Hole Connecting Plate

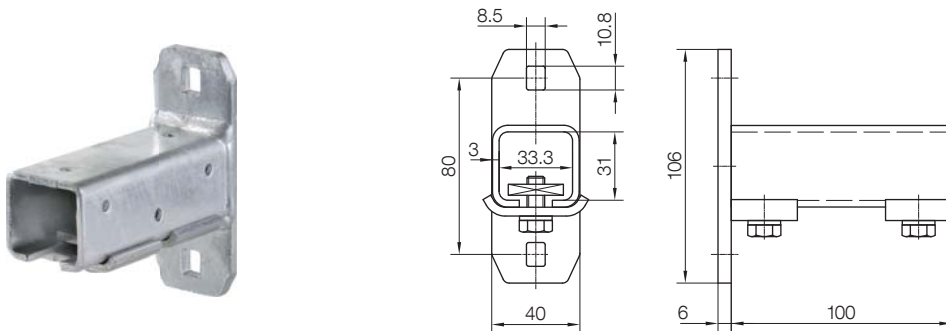

Order No.	Material	Suitable for Support Arm	Weight [kg]
020280	galvanized steel	020185, 020275	0.700

Bracket for Support Arms 40x40x2.5 to be bolted with 2-Hole Connecting Plate

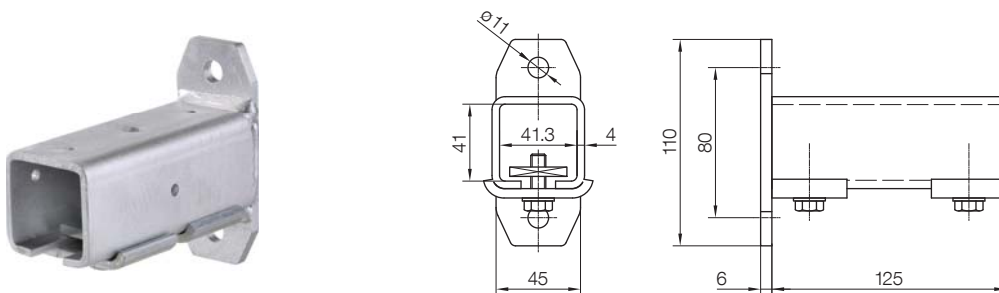

Order No.	Material	Suitable for Support Arm	Weight [kg]
020282	galvanized steel	020186, 020276	1.000

Bracket for Support Arms 40x40x2.5 to be bolted with 4-Hole Connecting Plate

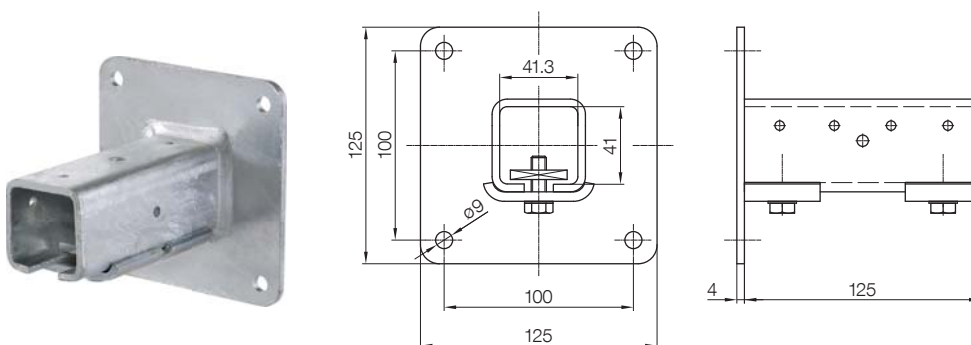

Order No.	Material	Suitable for Support Arm	Weight [kg]
020284	galvanized steel	020186, 020276	1.300

C-Rails and Accessories

Program 0230

Console Brackets to be bolted with 4-Hole Connecting Plate

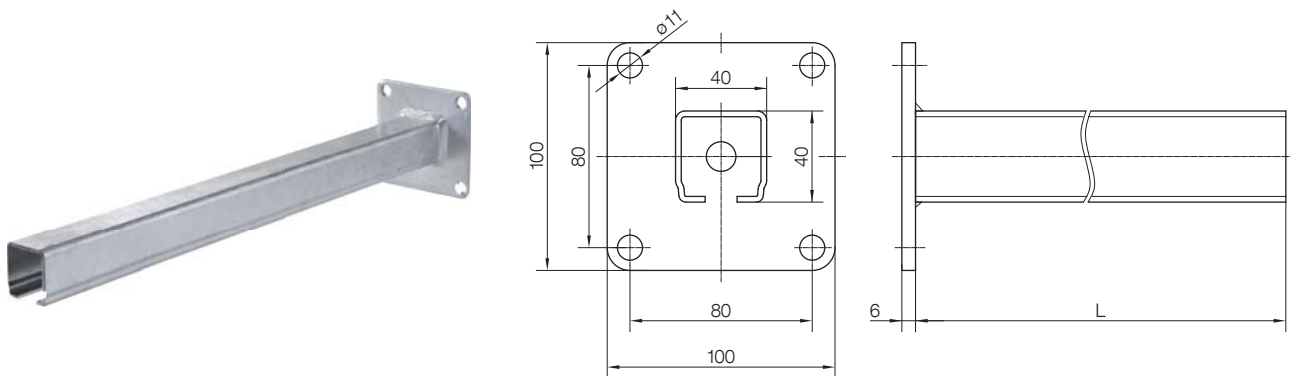

Order No.	Material	I [mm]	Weight [kg]
020206-0500	galvanized steel	500	1.700
020206-0630		630	2.000
020206-0800		800	2.450
020206-1000		1000	2.800

Brackets, bare to be welded

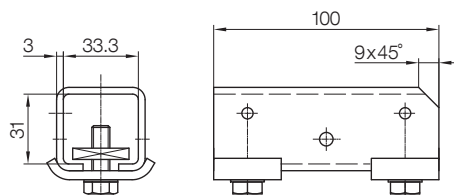

Order No. 020285

- Material
 - bracket: bare steel
 - fasteners: galvanized steel
- Suitable for support arm type: 020185, 020275
- Weight: 0.420 kg

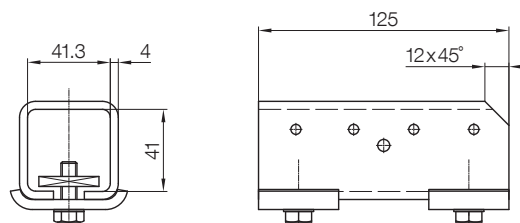

Order No. 020286

- Material
 - bracket: bare steel
 - fasteners: galvanized steel
- Suitable for support arm type: 020186, 020276
- Weight: 0.730 kg

C-Rails and Accessories

Program 0230

Girder Clips, Clamping Thickness 4 - 20 mm

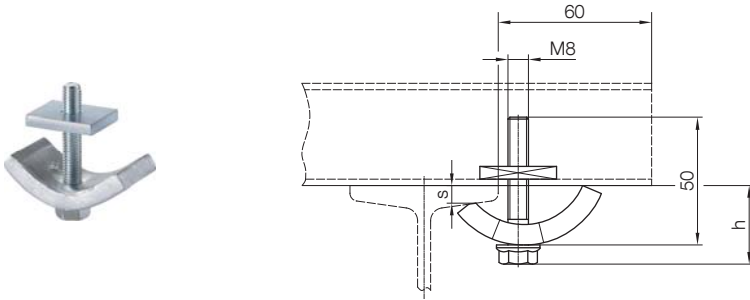

Order No.	Material	Weight [kg]
020180-08	galvanized steel	0.150
020480-08	stainless steel V4A	0.150

Clamping Thickness	s	4	6	8	10	12	16	20
Mounting Height	h	31	32	33	34	35	37	40

Girder Clips, Clamping Thickness 18 - 36 mm

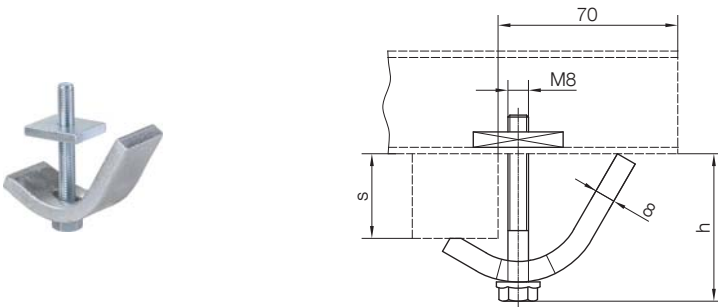

Order No.	Material	Weight [kg]
020180-08x36	galvanized steel	0.220
020480-08x36	stainless steel V4A	0.220

Clamping Thickness	s	18-20	20-24	24-28	28-32	32-36
Mounting Height	h	42-44	44-48	48-52	52-56	56-60

Girder Clips, Twist-Secured, Clamping Thickness 6 - 25 mm

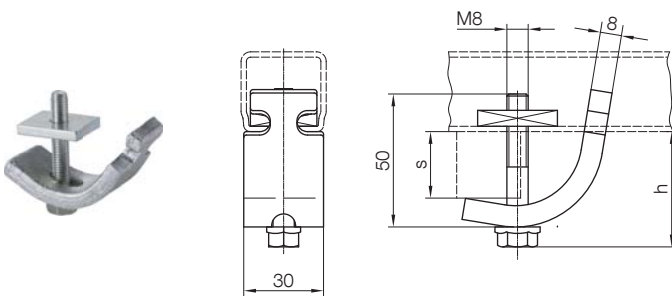

Order No.	Material	Weight [kg]
020181-08	galvanized steel	0.190

Clamping Thickness	s	6 - 25
Mounting Height	h	32 - 40

C-Rails and Accessories Program 0230

Application Examples for Support Arm and C-Rail Fastening with Support Arms – unpunched

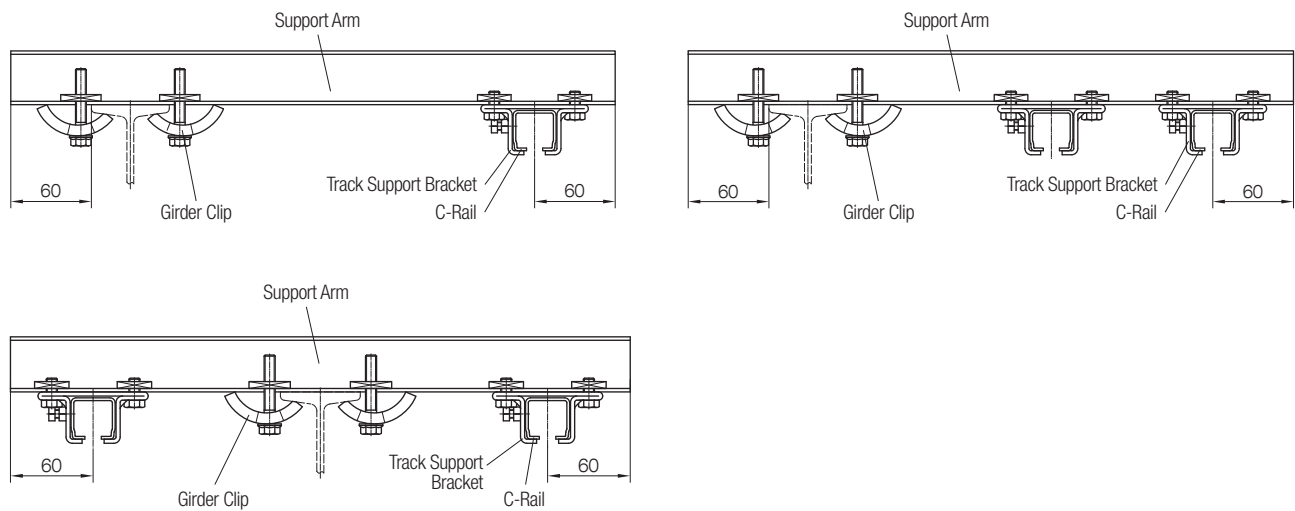

Application Examples for Support Arm and C-Rail Fastening with Support Arms – punched

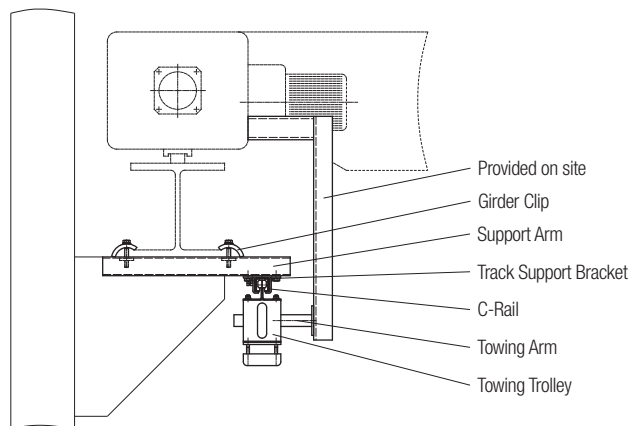

Application Example for Support Arm and C-Rail Fastening with Welded Brackets

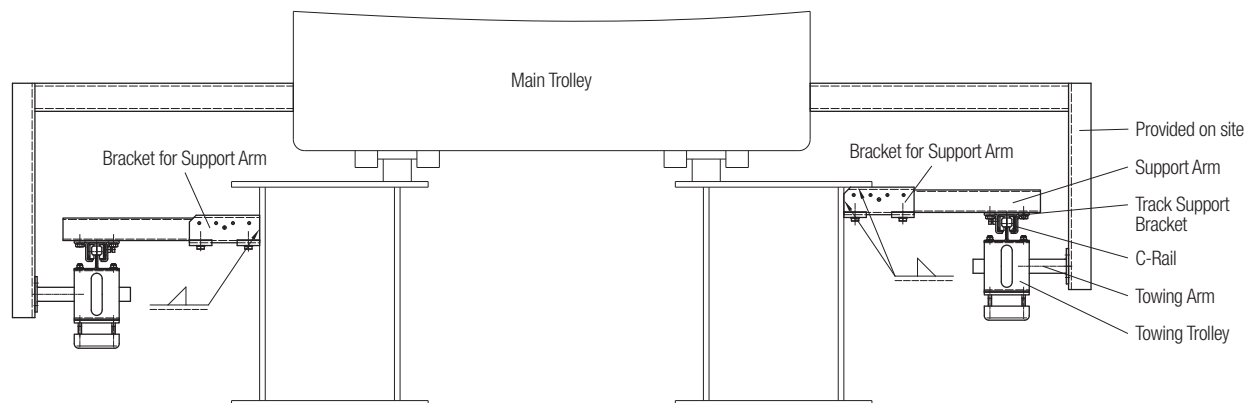

C-Rails and Accessories

Program 0230

End Stop 30x24

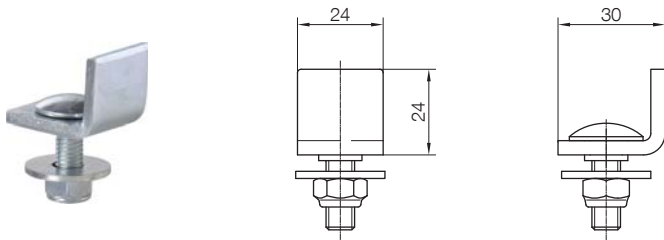

- Order No. 023215**
- Material: galvanized steel
 - Weight: 0.060 kg

End Stop with Rubber Buffer

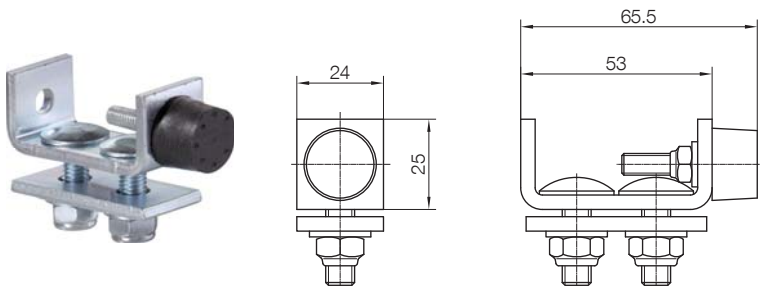

- Order No. 023218**
- Material: galvanized steel, rubber buffer
 - Weight: 0.150 kg

End Stop without Rubber Buffer

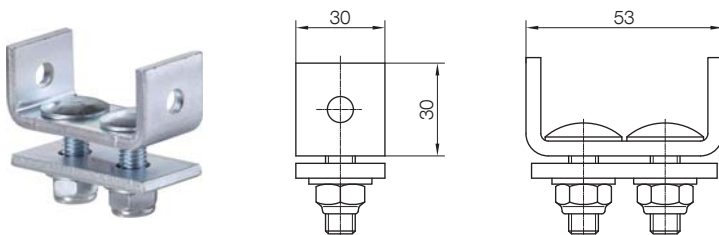

Order No.	Material	Weight [kg]
023219	galvanized steel	0.130
023419	stainless steel V4A	0.130

Application Example for End Stop Assembly

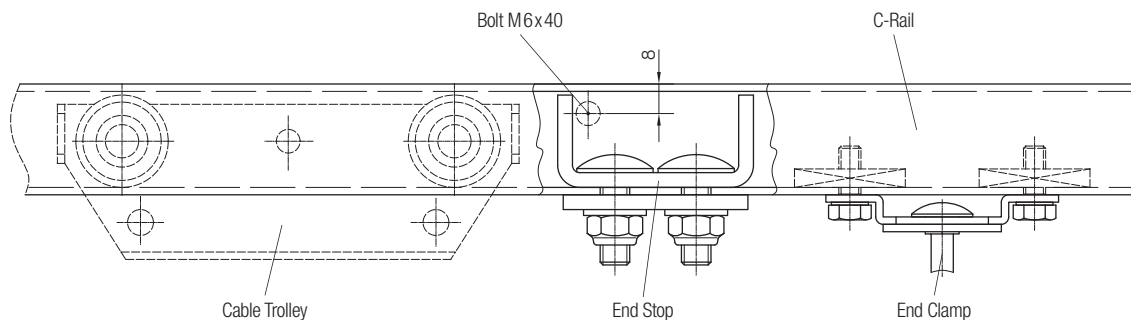

Notes

The end stop is fixed in the C-rail between the end clamp and the cable trolley. This helps to prevent cable trolleys running into the end clamp.

For control supply systems with manually driven ideal control trolleys an end stop mounted at the end of the C-rail prevents the ideal control trolley from travelling out of the rail.

C-Rails and Accessories

Program 0230

Towing Arms

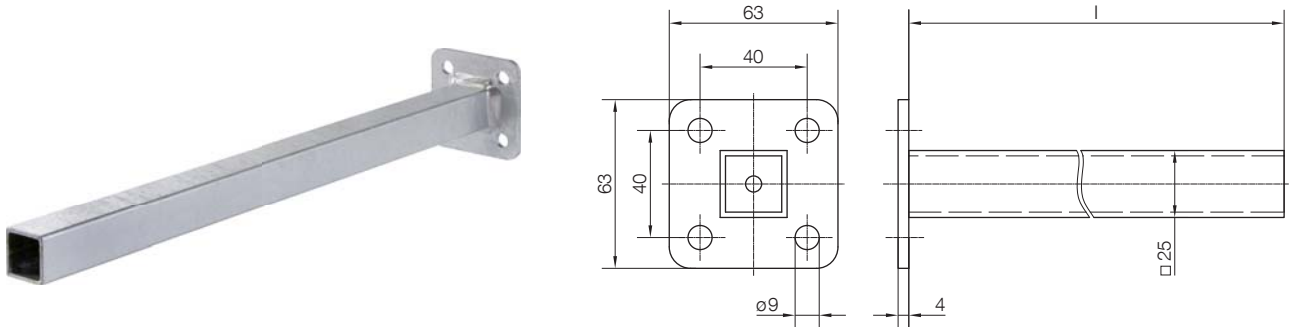

Order No.	Material	l [mm]	Weight [kg]
020195-400	galvanized steel	400	0.600
020195-630		630	1.000
020495-400	stainless steel V4A	400	0.600
020495-630		630	1.000

End Caps

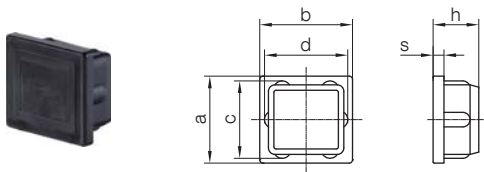

Order No.	For C-Rail	Material	a [mm]	b [mm]	c [mm]	d [mm]	s [mm]	h [mm]	Weight [kg]
020662-30	023200	plastic	30	32	27	29	4	18	0.005
020662-31	023201		30	30	28	28	5	16	0.004

Clips with or without Cable Tie

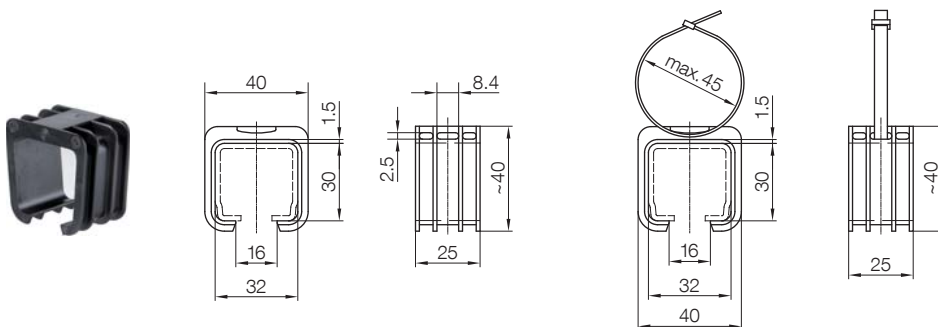

Order No.	Remarks	Material	Weight [kg]
023790	without cable tie	plastic	0.010
023790-1	with cable tie		0.012

Cable Trolleys for Flat Cables

Program 0230

Plastic Cable Trolleys



Technical details

- Trolley body and cable supports: plastic
- Hardware: galvanized steel
- Temperature range: -30°C to +60°C

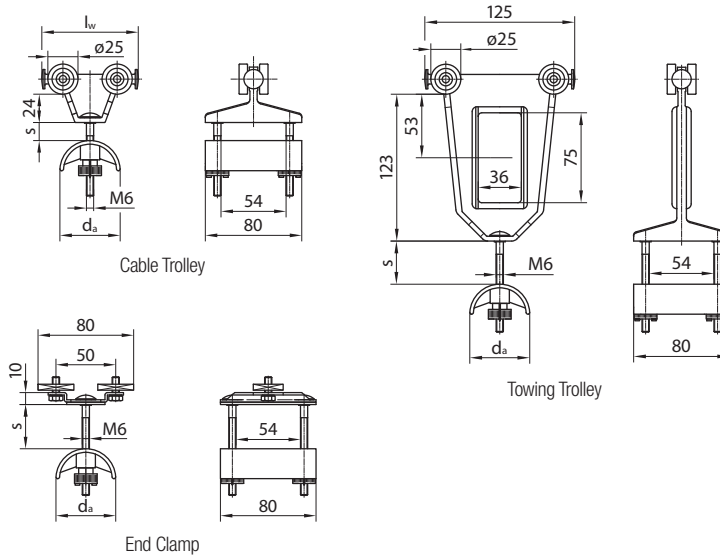

Cable Trolley Order No.	[kg]	Towing Trolley Order No.	[kg]	End Clamp Order No.	[kg]	d _a	l _w	s	Max. Load Capacity [kg]	Max. Travel Speed [m/min]	Roller Type
						[mm]	[mm]	[mm]			
023910	0.11	023915	0.15	023919	0.175	50	80	15	6.3	40	(1)
023943	0.12	023958	0.16	023269	0.210	50	80	15			
023953	0.13	023958	0.16	023269	0.210	50	125	36	8.0	40	(2)
023973	0.15	023978	0.18	023279	0.215	80	125	22			
023941	0.19	023956	0.23	023269	0.210	50	80	15	10.0	40	(3)
023951	0.19	023956	0.23	023269	0.210	50	125	36			
023971	0.23	023976	0.25	023279	0.215	80	125	22			

Roller type

- (1) Plastic roller and plastic friction bearing
- (2) Plastic roller and bronze friction bearing
- (3) Ball bearing, galvanized

Cable Trolleys for Flat Cables

Program 0230

Steel Cable Trolleys with Plastic Cable Support

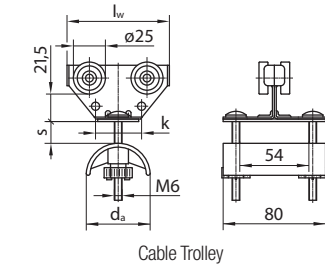

Cable Trolley

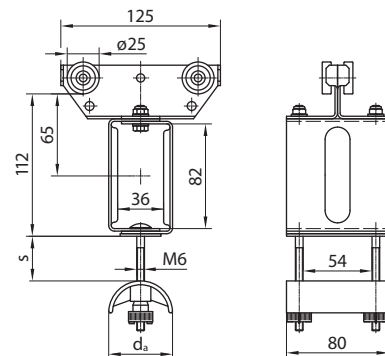

Towing Trolley

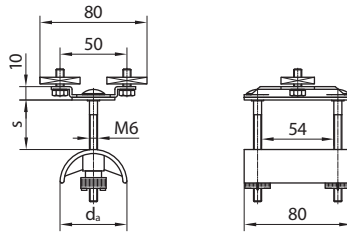

End Clamp

Technical details

- Trolley body: galvanized steel
- Cable supports: plastic
- Hardware: galvanized steel
- Standard rollers: ball bearings, galvanized with ZZ-sealing
- Temperature range: -30°C to +80°C
- Stainless steel rollers: ball bearing, V4A with 2RS-sealing
- Temperature range stainless steel/plastic, acid-resistant: -10°C to +80°C

Cable Trolley Order No.	[kg]	Towing Trolley Order No.	[kg]	End Clamp Order No.	[kg]	d_a	l_w	s	k	Max. Load Capacity [kg]	Max. Travel Speed [m/min]
						[mm]	[mm]	[mm]	[mm]		
023261	0.275	023267	0.740	023269	0.210	50	80	15	36	10.0	50
023263	0.355	023267	0.740	023269	0.210	50	125	36	80		
023271	0.385	023277	0.770	023279	0.215	80	125	22	80		
023461	0.280	023467	0.750	023469	0.210	50	80	15	-	6.3	50
023463	0.365	023467	0.750	023469	0.210	50	125	36	80		
023471	0.390	023477	0.775	023479	0.215	80	125	22	80		

Note

For a better sealing the standard rollers (ZZ) can also be provided with a 2 RS-sealing.
The order no. has to be completed with the variation designation .../010.

Cable Trolleys for Flat Cables

Program 0230

Steel Cable Trolleys, Light Series without Buffer

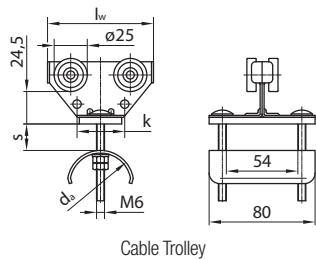

Cable Trolley

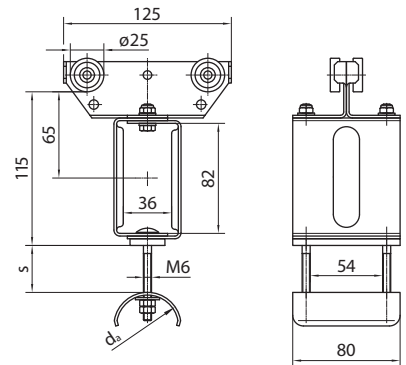

Towing Trolley

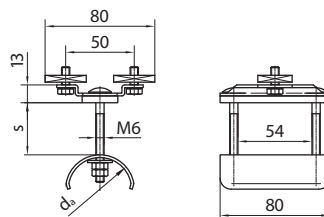

End Clamp

Technical details

- Trolley body and cable supports: galvanized steel
- Hardware: galvanized steel
- Standard rollers: ball bearing, galvanized with ZZ-sealing
- Temperature range: -30°C to +80°C
- Stainless steel rollers: ball bearing, V4A with 2RS-sealing
- Temperature range stainless steel: -10°C to +80°C

Cable Trolley Order No.	[kg]	Towing Trolley Order No.	[kg]	End Clamp Order No.	[kg]	d _a	l _w	s	k	Max. Load Capacity [kg]	Max. Travel Speed [m/min]
023561	0.360	023567	0.825	023569	0.270	50	80	15	36	16	63
023563	0.440	023567	0.825	023569	0.270	50	125	36	80		
023571	0.485	023577	0.870	023579	0.325	80	125	22	80		
023431	0.365	023435	0.750	023438	0.270	50	80	15	-	10	63
023432	0.445	023435	0.830	023438	0.270	50	125	36	80		
023433	0.495	023436	0.880	023439	0.325	80	125	22	80		

Steel Cable Trolleys, Light Series with Buffer

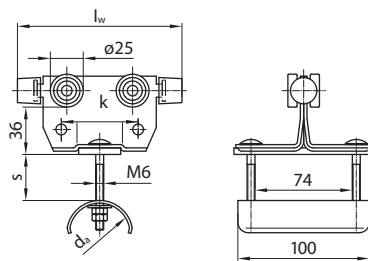

Cable Trolley

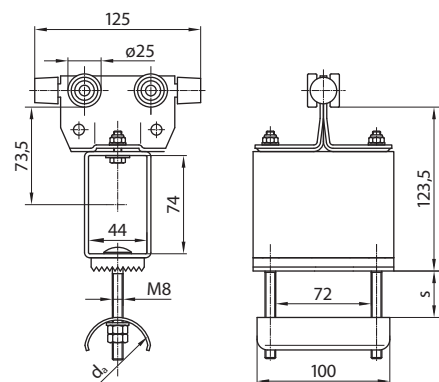

Towing Trolley

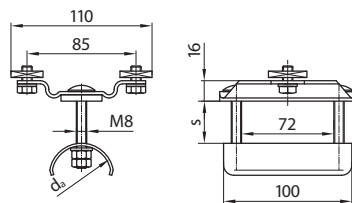

End Clamp

Technical details

- Trolley body and cable supports: galvanized steel
- Hardware: galvanized steel
- Standard rollers: ball bearing, galvanized with ZZ-sealing
- Temperature range: -30°C to +80°C

Cable Trolley Order No.	[kg]	Towing Trolley Order No.	[kg]	End Clamp Order No.	[kg]	d _a	l _w	s	k	Max. Load Capacity [kg]	Max. Travel Speed [m/min]
023509-125x100	0.58	023519-125x100	1.21	024289-100x038	0.37	50	125	35	58	16	80
023510-125x100	0.65	023520-125x100	1.26	024290-100x038	0.44	80		20	58		

Note

For a better sealing the standard rollers (ZZ) can also be provided with a 2 RS-sealing. The order no. has to be completed with the variation designation .../010.

Cable Trolleys for Flat Cables

Program 0230

Steel Cable Trolleys, Heavy Series

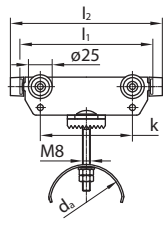

Cable Trolley

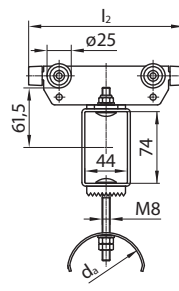
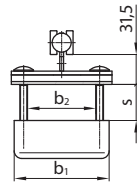

Towing Trolley

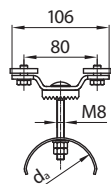
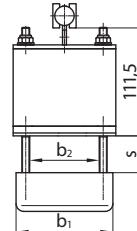

End Clamp

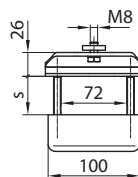

Technical details

- Trolley body and cable supports: galvanized steel
- Hardware: galvanized steel
- Standard rollers: ball bearings, galvanized with ZZ-sealing
- Temperature range: -30°C to +80°C
- Stainless steel rollers: ball bearings, V4A, 2RS-sealing
- Temperature range stainless steel: -10°C to +80°C

Cable Trolley Order No.	[kg]	Towing Trolley Order No.	[kg]	End Clamp Order No.	[kg]	d_a	$l_1^{1)}$	$l_2^{2)}$	b_1	b_2	s	k	Max. Load Capacity [kg]	Max. Travel Speed [m/min]
						[mm]	[mm]	[mm]	[mm]	[mm]	[mm]	[mm]		
023330-140x100	0.69	023335-160x100	1.24	024230-100x062	0.70	80	140	-	100	72	30	97	20	80
023330-160x100	0.70	023335-160x100	1.24	024230-100x062	0.70		-	160	100	72	38			
023330-160x160	0.90	023335-160x160	1.56	024230-160x062	0.94		-	160	160	132	38			
023330-180x100	0.76	023335-200x100	1.31	024230-100x062	0.70		180	-	100	72	50	137	20	80
023330-200x100	0.77	023335-200x100	1.31	024230-100x062	0.70		-	200	100	72	58			
023330-200x160	0.97	023335-200x160	1.63	024230-160x062	0.94		-	200	160	132	58			
023332-160x100	0.82	023337-160x100	1.36	024232-100x042	0.80	125	-	160	100	72	15	97	20	80
023332-160x160	1.11	023337-160x160	1.77	024232-160x042	1.13		-	160	160	132	15			
023332-180x100	0.86	023337-200x100	1.41	024232-100x042	0.80		180	-	100	72	27			
023332-200x100	0.87	023337-200x100	1.41	024232-100x042	0.80		-	200	100	72	35			
023332-200x160	1.16	023337-200x160	1.82	024232-160x042	1.13		-	200	160	132	35			
023332-230x100	0.93	023337-250x100	1.48	024232-100x062	0.82		230	-	100	72	52	187	20	80
023332-250x100	0.94	023337-250x100	1.48	024232-100x062	0.82	-	250	100	72	60				
023332-250x160	1.24	023337-250x160	1.90	024232-160x062	1.15	-	250	160	132	60				
023333-200x100	1.02	023338-200x100	1.56	024233-100x042	1.00	160	-	200	115	72	18	137	20	80
023333-200x160	1.40	023338-200x160	2.06	024233-160x042	1.40		-	200	175	132	18			
023333-230x100	0.94	023338-250x100	1.63	024233-100x042	1.00		230	-	115	72	35			
023333-250x100	0.95	023338-250x100	1.63	024233-100x042	1.00		-	250	115	72	42			
023333-250x160	1.34	023338-250x160	2.14	024233-160x042	1.40		-	250	175	132	42			
023334-320x100	1.19	023339-320x100	1.73	024234-100x062	1.12		200	-	320	115	72	54	257	20
023830-125x100	0.65	023835-125x100	1.19	024830-100x062	0.70	80	-	125	100	72	20	62	10	80
023830-160x100	0.70	023835-160x100	1.24	024830-100x062	0.70		-	160	100	72	38	97		
023832-200x100	0.87	023837-200x100	1.41	024832-100x042	0.80	125	-	200	100	72	35	137	10	80
023832-200x160	1.16	023837-200x160	1.82	024832-160x042	1.13		-	200	160	132	35			
023832-250x100	0.94	023837-250x100	1.48	024832-100x062	0.82		-	250	100	72	60	187		
023832-250x160	1.24	023837-250x160	1.90	024832-160x062	1.15		-	250	160	132	60			
023833-200x100	1.02	023838-200x100	1.56	024833-100x042	1.00	160	-	200	115	72	18	137	10	80
023833-200x160	1.40	023838-200x160	2.06	024833-160x042	1.40		-	200	175	132	18			
023833-250x100	0.95	023838-250x100	1.63	024833-100x042	1.00		-	250	115	72	42	187		
023833-250x160	1.34	023838-250x160	2.14	024833-160x042	1.40		-	250	175	132	42			

1) without buffer 2) with buffer

Note

For a better sealing the standard rollers (ZZ) can also be provided with a 2 RS-sealing. The order no. has to be completed with the variation designation .../010.

Cable Trolleys for Round Cables Program 0230

Plastic Cable Trolleys with Ball Joint for Cable Clip 020131



Technical details

- Trolley body and ball joint: plastic
- Hardware: galvanized steel
- Temperature range: -30°C to +60°C

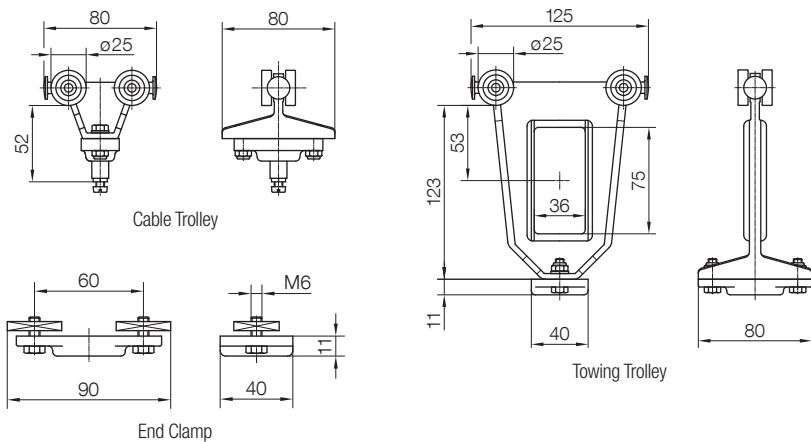

Cable Trolley Order No.	[kg]	Towing Trolley Order No.	[kg]	End Clamp Order No.	[kg]	Roller Type	Max. Load Capacity [kg]	Max. Travel Speed [m/min]
023930	0.095	023935	0.130	023299	0.090	plastic roller, plastic friction bearing	6.3	32
023993	0.095	023998	0.130	023299	0.090	plastic roller, bronze friction bearing	8	32
023991	0.160	023996	0.195	023299	0.090	ball bearing, steel	10	32

Steel Cable Trolleys with Ball Joint for Cable Clips 020131 or 020431



Technical details

- Trolley body: galvanized steel
- Ball joint: plastic
- Hardware: galvanized steel
- Standard rollers: ball bearings, galvanized with ZZ-sealing
- Temperature range: -30°C to +60°C
- Stainless steel rollers: ball bearings, V4A with 2RS-sealing
- Temperature range stainless steel/ plastic, acid-resistant: -10°C to +60°C

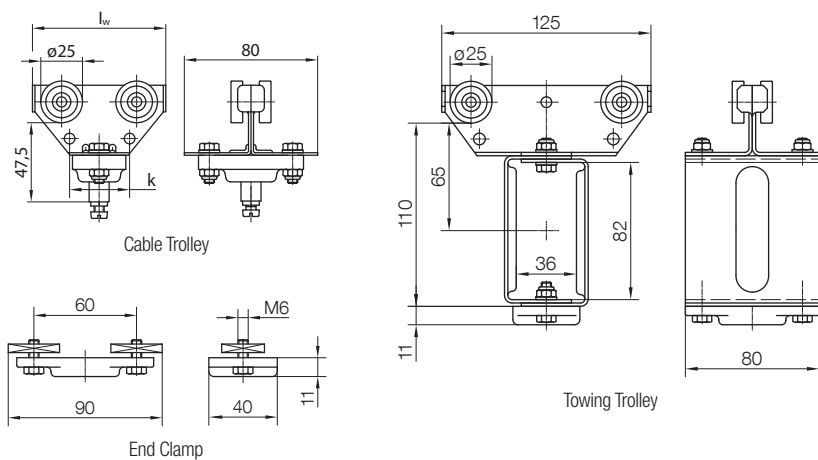

Cable Trolley Order No.	[kg]	l _w [mm]	k [mm]	Towing Trolley Order No.	[kg]	End Clamp Order No.	[kg]	Max. Load Capacity [kg]	Max. Travel Speed [m/min]
023291	0.260	80	36	023297	0.570	023299	0.090	10	40
023290	0.320	125	80	023297					
023491	0.260	80	-	023497	0.57	023499	0.090	6.3	40
023490	0.320	125	80	023497		023499			

Notes

- For a better sealing the standard rollers (ZZ) can also be provided with a 2 RS-sealing
The order no. has to be completed with the variation designation .../010
- For max. 3 cables in separate cable clips, suspended one below the other
- Appropriate for cable clips: 020131-16, 020131-25, 020131-36 (only suited for trolley length 125 mm)
020431-16, 020431-25, 020431-36 (only suited for trolley length 125 mm)

Cable Trolleys for Round Cables Program 0230

Steel Cable Trolleys with Bracket for Cable Clips 020133



Technical details

- Trolley body and bracket: galvanized steel
- Hardware: galvanized steel
- Standard rollers: ball bearings, galvanized with ZZ-sealing
- Temperature range: -30°C to +80°C
- Stainless steel rollers: ball bearings, V4A with 2RS-sealing
- Temperature range stainless steel: -10°C to +80°C

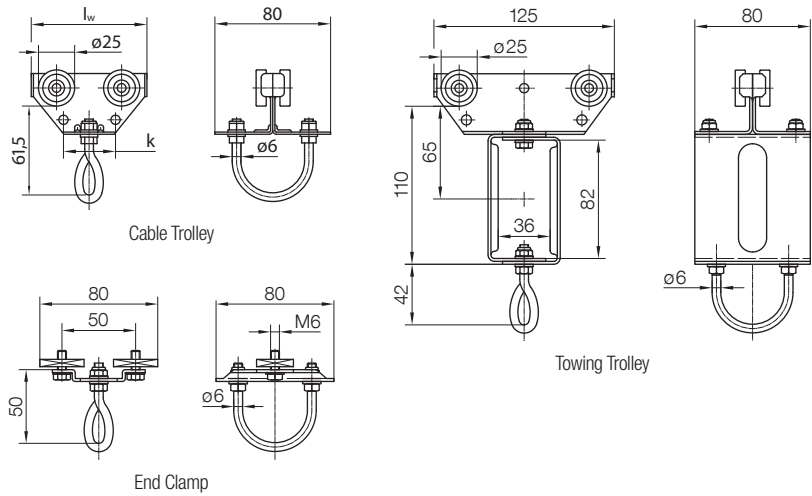

Cable Trolley Order No.	[kg]	l_w [mm]	k [mm]	Towing Trolley Order No.	[kg]	End Clamp Order No.	[kg]	Max. Load Capacity [kg]	Max. Travel Speed [m/min]
	023293	0.250	80		36		023295		
023192	0.310	125	80	023295	0.600	023298	0.200	16	63
023493	0.250	80	-	023495	0.600	023498	0.200	10	63
023492	0.310	125	80	023495	0.600	023498	0.200	10	63

Note

For a better sealing the standard rollers (ZZ) can also be provided with a 2 RS-sealing.
The order no. has to be completed with the variation designation .../010.

Cable Trolleys for Round Cables

Program 0230

Cable Clips for Fixation at the Ball Joint

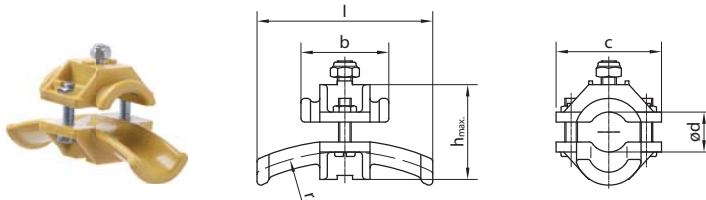

Order No.	For Cable- ϕ d [mm]	r [mm]	l [mm]	h [mm]	b [mm]	c [mm]	Material	Weight [kg]
020131-16	10 ... 16	80	70	38	35	42	plastic hardware: galvanized steel	0.040
020131-25	17 ... 25	125	100	47	50	50		0.060
020131-36	26 ... 36	180	140	58	70	64		0.120
020431-16	10 ... 16	80	70	38	35	42	plastic, acid-resistant hardware: stainless steel V4A	0.040
020431-25	17 ... 25	125	100	47	50	50		0.060
020431-36	26 ... 36	180	140	58	70	64		0.120

Cable Clips for Fixation at the Bracket

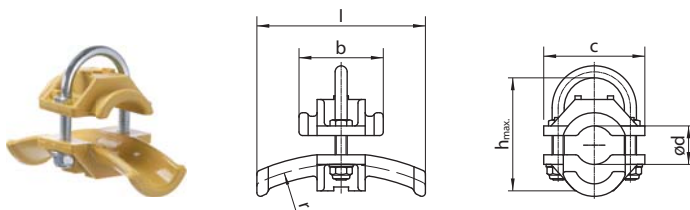

Order No.	for Cable- ϕ d [mm]	r [mm]	l [mm]	h [mm]	b [mm]	c [mm]	Material	Weight [kg]
020133-16	10 ... 16	80	70	38	35	42	plastic hardware: galvanized steel	0.050
020133-25	17 ... 25	125	100	47	50	50		0.070
020133-36	26 ... 36	180	140	58	70	64		0.140
020133-50	37 ... 50	250	200	80	100	90	aluminum hardware: galvanized steel	0.280
020433-16	10 ... 16	80	70	38	35	42	plastic, acid-resistant hardware: stainless steel V4A	0.040
020433-25	17 ... 25	125	100	47	50	50		0.060
020433-36	26 ... 36	180	140	58	70	64		0.120

Hose Clip for Fixation at the Ball Joint

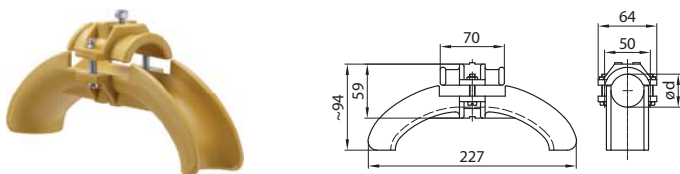

Order No. 020130-36

- Material: plastic
- Hardware: galvanized steel
- For hose- ϕ d = 26 - 36 mm
- Weight: 0.130 kg

Hose Clip for Fixation at the Bracket

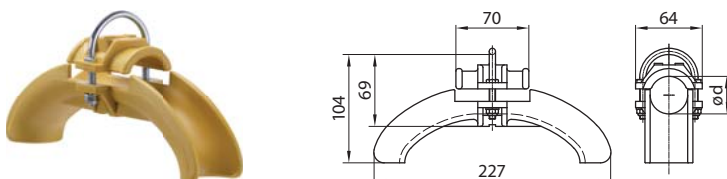

Order No. 020138-36

- Material: plastic
- Hardware: galvanized steel
- For hose- ϕ d = 26 - 36 mm
- Weight: 0.150 kg

Cable Trolleys for Round Cables

Program 0230

Steel Cable Trolleys, Heavy Series
for Clamping of Round Cables with a max. Difference in Diameter of 6 mm

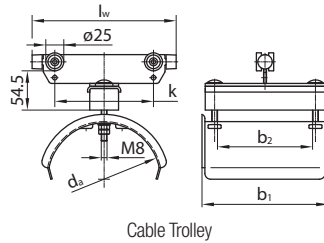

Cable Trolley

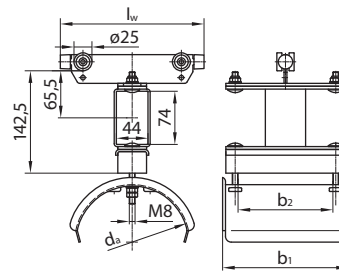

Towing Trolley

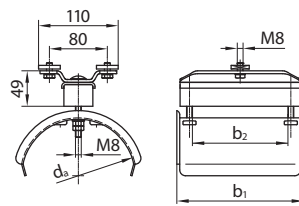

End Clamp

Technical details

- Trolley body and cable supports: galvanized steel
- Hardware: galvanized steel
- Standard rollers: ball bearings, galvanized with ZZ-sealing
- Temperature range: -30°C to +80°C
- Stainless steel rollers: ball bearings, V4A with 2RS-sealing
- Temperature range stainless steel: -10°C to +80°C

Cable Trolley Order No.	[kg]	Towing Trolley Order No.	[kg]	End Clamp Order No.	[kg]	d _a [mm]	l _w [mm]	b ₁ [mm]	b ₂ [mm]	k [mm]	Max. Load Capacity [kg]	Max. Travel Speed [m/min]
023345-200x100	1.20	023347-200x100	1.68	024463-100	1.20	160	200	115	72	137	20	80
023345-200x160	1.59	023347-200x160	2.14	024463-160	1.60	160	200	175	132	137		
023345-250x100	1.35	023347-250x100	1.83	024464-100	1.30	200	250	115	72	187		
023345-250x160	1.88	023347-250x160	2.43	024464-160	1.85	200	250	175	132	187		
023345-250x200	2.26	023347-250x200	2.86	024464-200	2.25	200	250	215	172	187		
023345-320x200	2.63	023347-320x200	3.23	024465-200	2.50	250	320	215	172	257		
023845-200x100	1.20	023847-200x100	1.68	024963-100	1.20	160	200	115	72	137	10	80
023845-200x160	1.59	023847-200x160	2.14	024963-160	1.60	160	200	175	132	137		
023845-250x100	1.35	023847-250x100	1.83	024964-100	1.30	200	250	115	72	187		
023845-250x160	1.88	023847-250x160	2.43	024964-160	1.85	200	250	175	132	187		

Note

For a better sealing the standard rollers (ZZ) can also be provided with a 2 RS-sealing.
The order no. has to be completed with the variation designation .../010.

Cable Trolleys for Round Cables Program 0230

Steel Cable Trolleys, Heavy Series
for Clamping of Round Cables with a max. Difference in Diameter of 16 mm

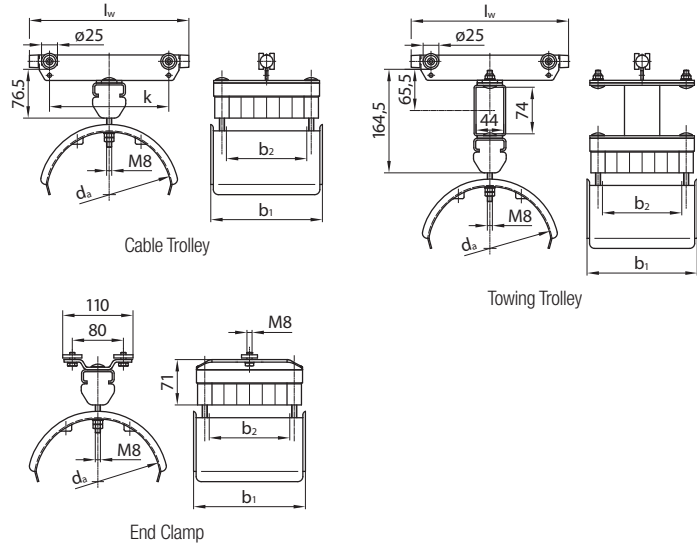

Technical details

- Trolley body and cable supports: galvanized steel
- Hardware: galvanized steel
- Standard rollers: ball bearings, galvanized with ZZ-sealing
- Temperature range: -30°C to +80°C

Cable Trolley Order No.	[kg]	Towing Trolley Order No.	[kg]	End Clamp Order No.	[kg]	d _a [mm]	l _w [mm]	b ₁ [mm]	b ₂ [mm]	k [mm]	Max. Load Capacity [kg]	Max. Travel speed [m/min]
023346-250x100	1.35	023348-250x100	1.83	024494-100	1.30	200	250	115	66	187	20	80
023346-250x160	1.88	023348-250x160	2.43	024494-160	1.85	200	250	175	126	187		
023346-250x200	2.26	023348-250x200	2.86	024494-200	2.25	200	250	215	166	187		
023346-320x200	2.63	023348-320x200	3.23	024495-200	2.50	250	320	215	166	257		

Note

For a better sealing the standard rollers (ZZ) can also be provided with a 2 RS-sealing.
The order no. has to be completed with the variation designation .../010.

Cable Trolleys and Accessories for Traversing, Program 0230

Cable Trolleys for Flat Cables with Additional Rollers

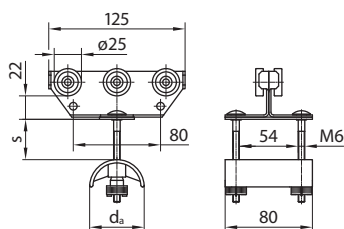

Cable Trolley 6-Rollers

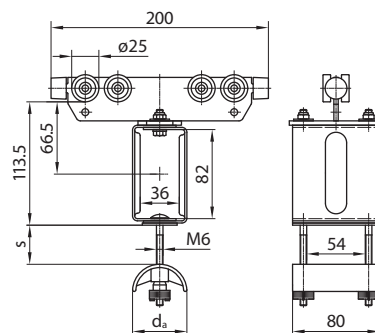

Towing Trolley 8-Rollers

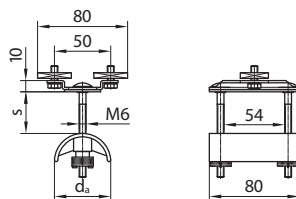

End Clamp

Technical details

- Trolley body: galvanized steel
- Cable supports: plastic
- Hardware: galvanized steel
- Standard rollers: ball bearings, galvanized with ZZ-sealing
- Temperature range: -30°C to +80°C

Cable Trolley Order No.	[kg]	Towing Trolley Order No.	[kg]	End Clamp Order No.	[kg]	d _a [mm]	s [mm]	Max. Load Capacity [kg]	Max. Travel Speed [m/min]
023315	0.410	023316	0.86	023269	0.210	50	35	16	63
023317	0.435	023318	0.90	023279	0.215	80	20		

Cable Trolleys for Round Cables with Additional Rollers

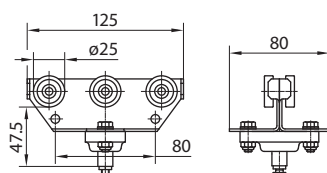

Cable Trolley 6-Rollers

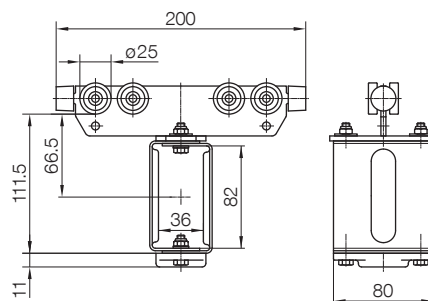

Towing Trolley 8-Rollers

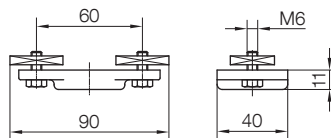

End Clamp

Technical details

- Trolley body: galvanized steel
- Cable supports: plastic
- Hardware: galvanized steel
- Standard rollers: ball bearings, galvanized with ZZ-sealing
- Temperature range: -30°C to +60°C

Cable Trolley Order No.	[kg]	Towing Trolley Order No.	[kg]	End Clamp Order No.	[kg]	Max. Load Capacity [kg]	Max. Travel Speed [m/min]
023319	0.41	023320	0.84	023299	0.09	16	50

Note

Suitable for cable clips: 020131-16, 020131-25, 020131-36

Cable Trolleys and Accessories for Traversing, Program 0230

Transfer Guide for C-Rail 023200

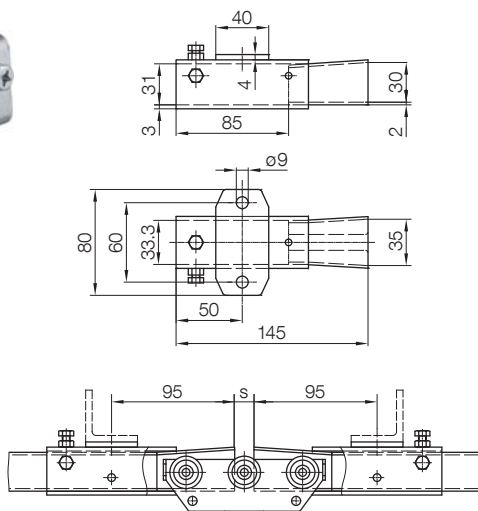

Order No. 023312

- Material: galvanized steel
- Weight: 0.500 kg

Notes

- Two transfer guides must be mounted at the transfer point with the inlet openings against each other
- The distance "s" must not exceed 15 mm
- Vertical deflection max. 1.5 mm
- Horizontal deflection max. 2.0 mm
- All cable trolleys, that pass this transition point must be provided with 3, the towing trolley with 4 pairs of rollers
- Cable trolleys that do not pass this transition point can be used in standard design
- The transfer guide can only be used in combination with the C-rail 023200

Cable Trolleys with Horizontal Guide Rollers for Applications with Increased Horizontal Forces

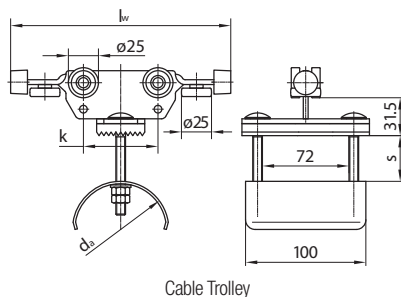

Cable Trolley

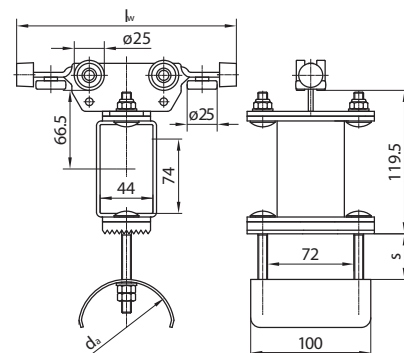

Towing Trolley

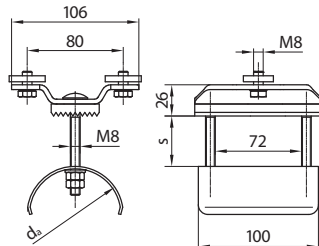

End Clamp

Technical details

- Trolley body: galvanized steel
- Cable supports: galvanized steel
- Hardware: galvanized steel
- Standard rollers: ball bearings, galvanized with ZZ-sealing
- Temperature range: -30°C to +80°C

Cable Trolley Order No.	[kg]	Towing Trolley Order No.	[kg]	End Clamp Order No.	[kg]	d _a [mm]	l _w [mm]	s [mm]	k [mm]	Max. Load Capacity [kg]	Max. Travel Speed [m/min]
023330-125x100/040	0.75	023335-125x100/040	1.35	024230-100x062	0.70	80	183	50	62	20	63
023330-160x100/040	0.80	023335-160x100/040	1.40	024230-100x062		80	218		97		
023332-200x100/040	0.87	023337-200x100/040	1.56	024232-100x062	0.82	125	258	137			
023332-250x100/040	1.04	023337-250x100/040	1.56	024232-100x062		125	308	187			

Ideal Control Unit Trolleys Program 0230

Ideal Control Unit Trolleys with Plug and Socket Connection – Basic Configuration

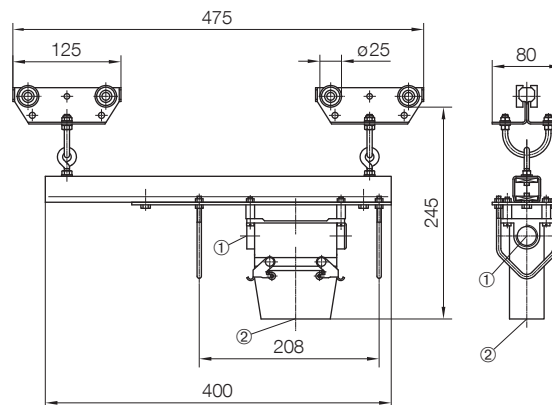

Technical details

- Trolley body and cross bar: galvanized steel
- Hardware: galvanized steel
- Standard rollers: ball bearings, galvanized with ZZ-sealing
- Temperature range: -30°C to +80°C

Note

Ideal control unit trolley with basic configuration without end clamp and without cable glands

Order No.	Number of Poles	Connecting Threads		Possible Attachment Parts	Weight [kg]	Max. Load Capacity [kg]	Max. Travel Speed [m/min]
		①	②				
023176-16	16+PE	M25x1.5	M25x1.5	end clamp 023269 and 023299 brake glider 023184 and brake trolley 023185	2.50	32	63
023176-24	24+PE	M25x1.5	M32x1.5		2.80		

Ideal Control Unit Trolleys with Plug and Socket Connection – Pre-Assembled

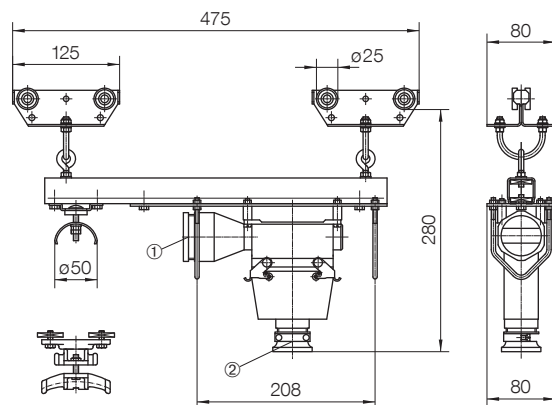

Technical details

- Trolley body and cross bar: galvanized steel
- Hardware: galvanized steel
- Standard rollers: ball bearings, galvanized with ZZ-sealing
- Temperature range: -30°C to +80°C

Note

Ideal control unit trolley pre-assembled with end clamp and with cable glands

Order No.	Number of Poles	Cable Glands		Type for	Possible Attachment Parts	Weight [kg]	Max. Load Capacity [kg]	Max. Travel Speed [m/min]
		①	②					
023178-16	16+PE	25x42	25x21	flat cables	brake glider 023184 brake trolley 023185	3.07	32	63
023178-24	24+PE	25x42	32x29			3.45		
023179-16	16+PE	25x29	25x21	round cables		2.86		
023179-24	24+PE	25x29	32x29			3.24		

Ideal Control Unit Trolleys Program 0230

Ideal Control Unit Trolley with Plastic Terminal Box – Basic Configuration

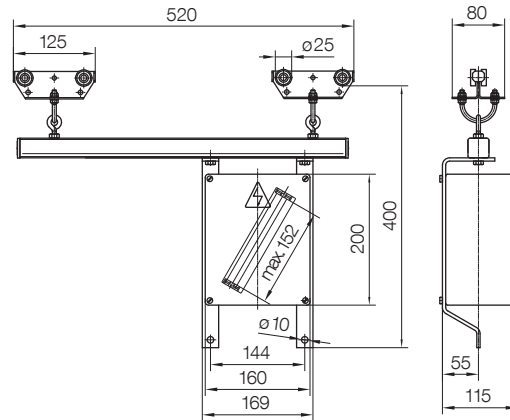

Technical details

- Trolley body and cross bar: galvanized steel
- Hardware: galvanized steel
- Standard rollers: ball bearings, galvanized with ZZ-sealing
- Temperature range: -30°C to $+80^{\circ}\text{C}$

Note

Ideal control unit trolley with basic configuration without end clamp, cable glands and terminals

Order No.	Possible Attachment Parts	Weight [kg]	Max. Load Capacity [kg]	Max. Travel Speed [m/min]
023180	end clamp 023269, 023299 brake glider 023184 brake trolley 023185	4.0	32	63

Ideal Control Unit Trolleys with Plastic Terminal Box – Pre-Assembled

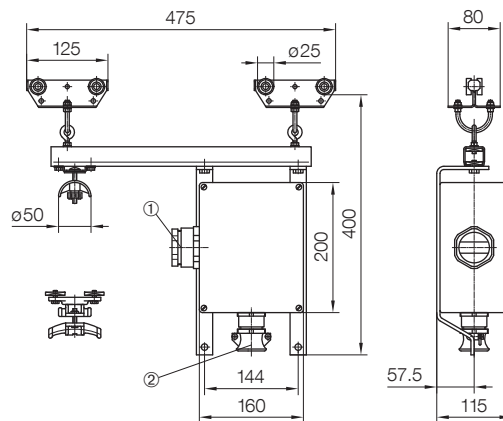

Technical details

- Trolley body and cross bar: galvanized steel
- Hardware: galvanized steel
- Standard rollers: ball bearings, galvanized with ZZ-sealing
- Temperature range: -30°C to $+80^{\circ}\text{C}$

Note

Ideal control unit trolley pre-assembled with end clamp, cable glands and terminals

Order No.	Number of Poles	Cable Glands		Types for	Possible Attachment Parts	Weight [kg]	Max. Load Capacity [kg]	Max. Travel Speed [m/min]
		①	②					
023174-16	16 + PE	50x42	25x21	flat cables	brake glider 023184 brake trolley 023185	4.81	32	63
023174-24	24 + PE	50x42	32x29			5.21		
023175-16	16 + PE	32x29	25x21	round cables	4.76			
023175-24	24 + PE	32x29	32x29		5.07			

Ideal Control Unit Trolleys Program 0230

Ideal Control Unit Trolleys with Terminal Box of Steel – Basic Configuration

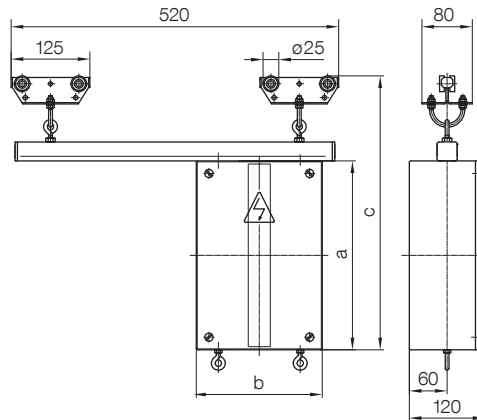

Technical details

- Trolley body and cross bar: galvanized steel Hardware: galvanized steel
- Standard rollers: ball bearings galvanized with ZZ-sealing
- Temperature range: -30°C to +80°C
- Stainless steel rollers: ball bearings V4A with 2RS-sealing
- Temp. range, stainless steel: -10°C to +80°C

Note

Ideal control unit trolley with basic configuration without end clamp, cable glands and terminals

Order No.	a [mm]	b [mm]	c [mm]	Possible Attachment Parts	Weight [kg]	Max. Load Capacity [kg]	Max. Travel Speed [m/min]
023181-150x150	150	150	300	end clamp 023269, 023299 brake glider 023184 brake trolley 023185	3.45	32	63
023181-200x200	200	200	350		5.00		
023181-300x200	300		450		6.00		
023481-200x200	200	200	350	end clamp 023469, 023499	5.00	20	63
023481-300x200	300		450	6.00			

Control Trolley Upper Parts

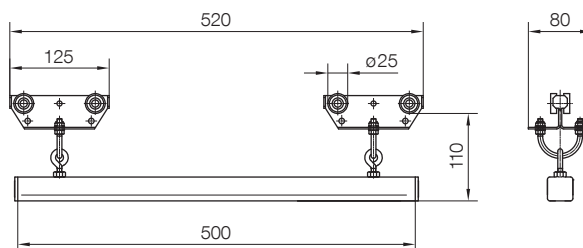

Technical details

- Trolley body and cross bar: galvanized steel
- Hardware: galvanized steel
- Standard rollers: ball bearings galvanized with ZZ-sealing
- Temperature range: -30°C to +80°C
- Stainless steel rollers: ball bearings V4A with 2RS-sealing
- Temp. range, stainless steel: -10°C to +80°C

Note

For a better sealing the standard rollers (ZZ) can also be provided with a 2RS-sealing. The order no. has to be completed with the variation designation ... / 010.

Order No.	Weight [kg]
023171	1.65
023871	1.65

Ideal Control Unit Trolley for Round Cables Program 0230

Basic Ideal Control Unit Trolleys for Round Cables

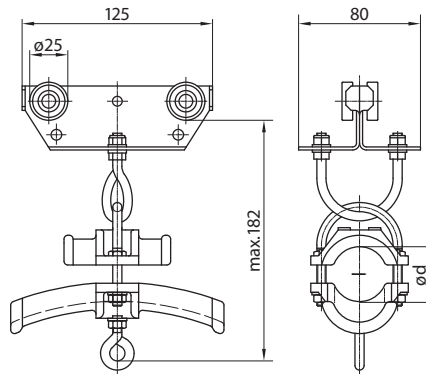

Technical details

- Trolley body and bracket: galvanized steel
- Hardware: galvanized steel
- Standard rollers: ball bearings, galvanized with ZZ-sealing
- Cable clips: plastic
- Temperature range: -30°C to +80°C

Order No.	for Cable- \varnothing d [mm]	Weight [kg]
023192-16	10 ... 16	0.370
023192-25	17 ... 25	0.400
023192-36	26 ... 36	0.460

Note

These control trolleys are used if the round cable is installed directly and without an additional terminal box up to the control station.

Accessories for Festoon Systems

Program 0230

Application Examples

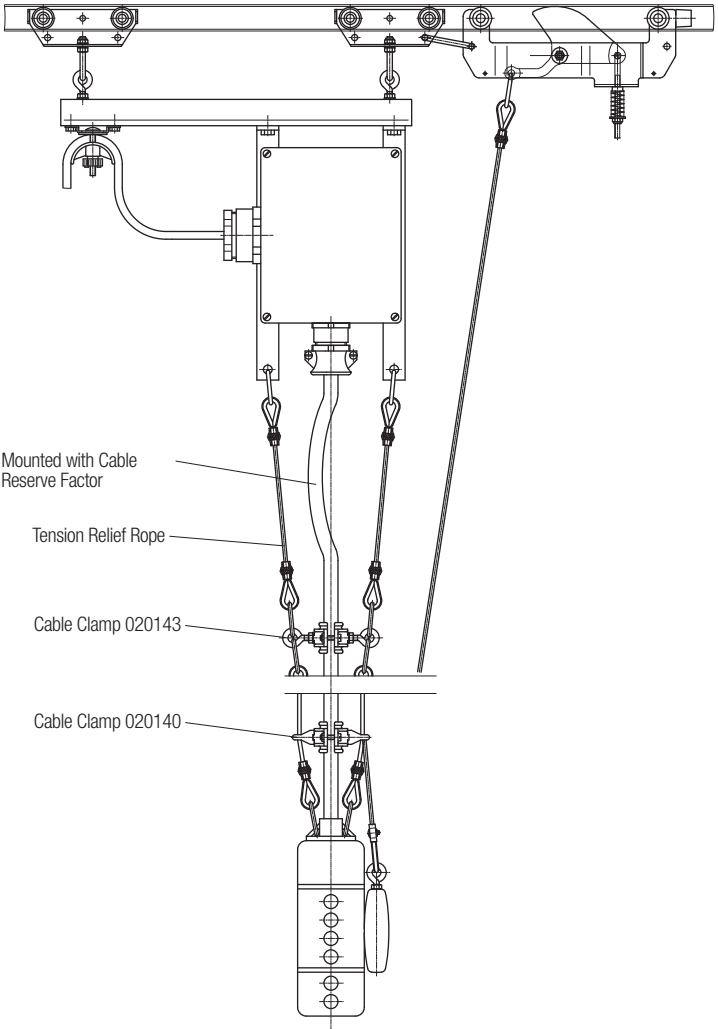
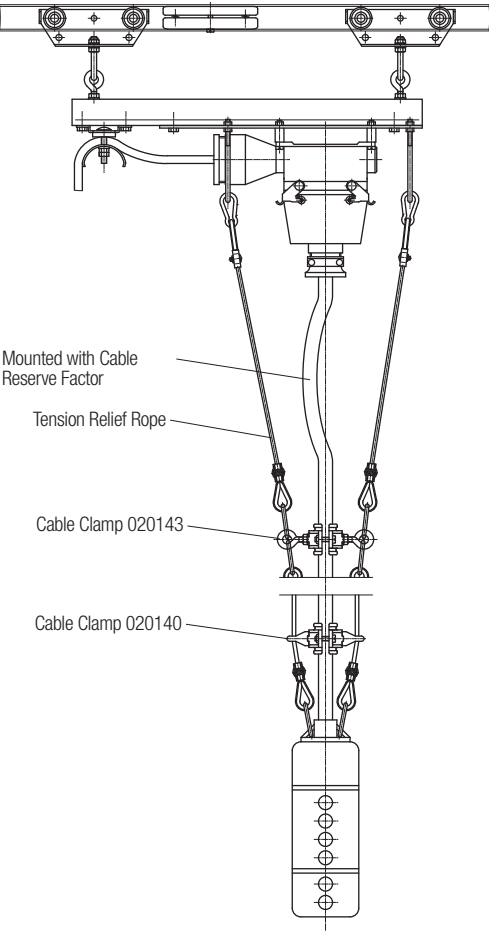
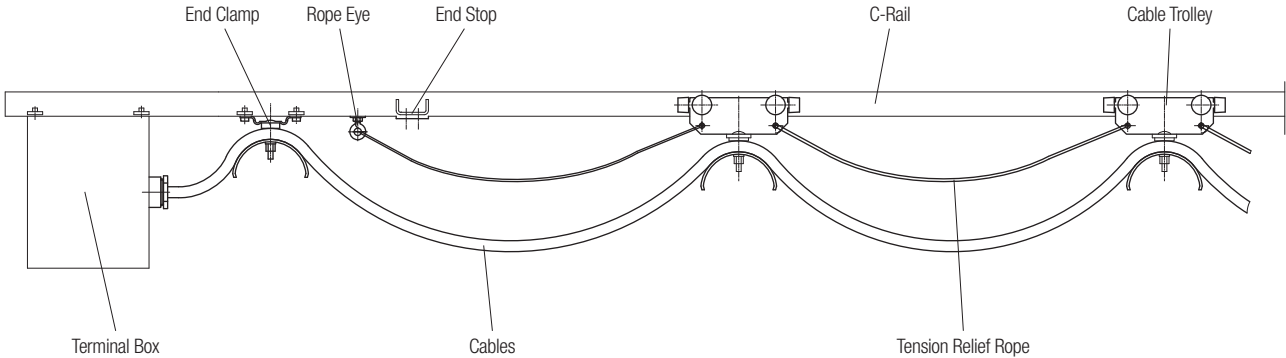

Note
 Special pendant station round cables with extruded steel ropes, that do not require separate tension relief devices, are listed in our cable catalog KAT0130-0002.

Accessories for Festoon Systems

Program 0230

Towing Ropes Pre-Assembled

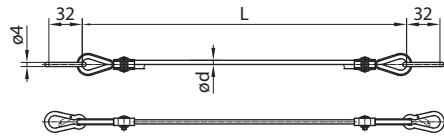

Order No.	ø d [mm]	Material	Weight [kg/m]
020318-04	4.0	plastic	0.13
020318-04/500	4.0	plastic, acid-resistant	0.13
020329-02,5	2.5	steel, PVC-covered	0.14

Ropes



Order No.	ø d [mm]	Material	Weight [kg/m]
020302-4	4.0	plastic	0.008
020301-4	4.0	plastic, acid-resistant	0.008
020305-02,5	2.5	steel, PVC-covered	0.009
020304-02	2.0	stainless steel V4A	0.015

Spring Safety Hook

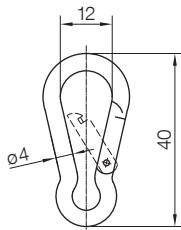

Order No.	Material	Weight [kg]
020215-40x4	galvanized steel	0.010
020415-40x4	stainless steel V4A	0.010

Rope Thimbles

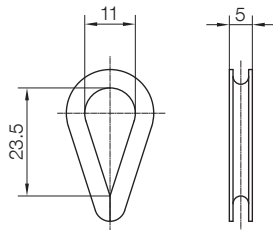

Order No.	Material	Weight [kg]
020120-3	galvanized steel	0.008
020450-3	stainless steel V4A	0.008

Simplex Rope Clip

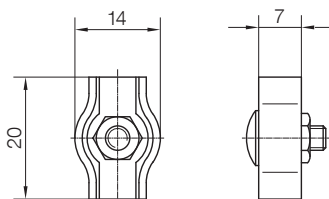

Order No.	Material	Weight [kg]
020122-3	galvanized steel	0.010
020452-3	stainless steel V4A	0.010

Design in stainless steel V4A or acid-resistant plastic

Accessories for Festoon Systems Program 0230

Rope Eyes

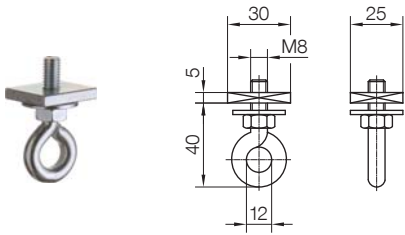

Order No.	Material	Weight [kg]
020218-08	galvanized steel	0.07
020458-08	stainless steel V4A	0.07

Cable Clamps

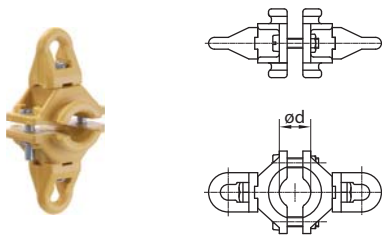

Cable Clamp Order No.	$\varnothing d$ [mm]	Material	Weight [kg]
020140-16	11 ... 16	plastic, hardware: galvanized steel	0.05
020140-25	17 ... 25		0.08
020140-36	26 ... 36		0.13

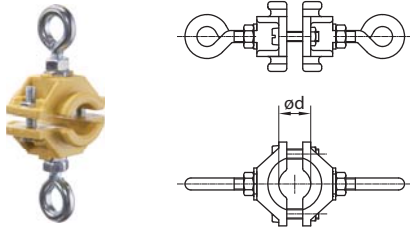

Cable Clamp Order No.	$\varnothing d$ [mm]	Material	Weight [kg]
020143-16	10 ... 16	plastic, hardware: galvanized steel	0.06
020143-25	17 ... 25		0.08
020143-36	26 ... 36		0.14

Brake Glider

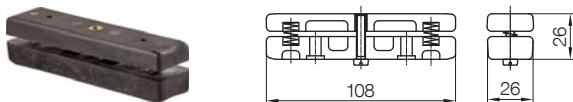

Brake Glider
Order No. 023184

- Basic material: plastic
- Hardware: galvanized steel
- Weight: 0.100 kg

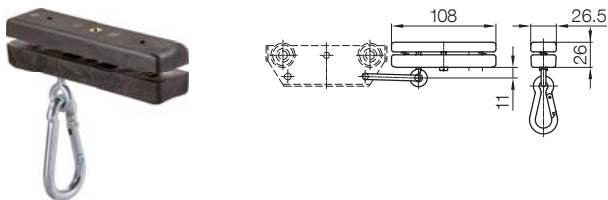

Brake Glider and hardware
Order No. 023199

- Basic material: plastic
- Hardware: galvanized steel
- Weight: 0.140 kg

Brake Trolley

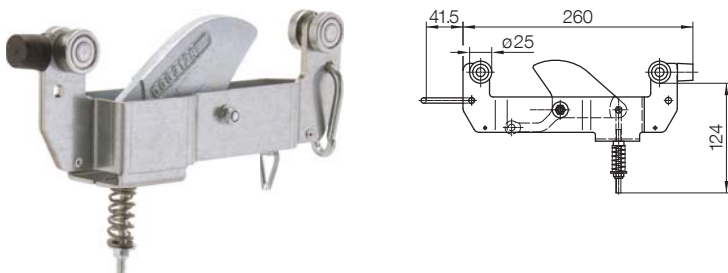

Order No. 023185

- Material: galvanized steel
- Hardware: galvanized steel
- Brake hammer: cast iron
- Weight: 1.400 kg

Accessories for Festoon Systems

Program 0230

Cable Trolley Upper Parts

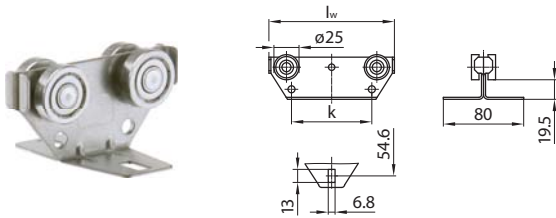

Cable Trolley Upper Parts without Buffer Order No.	l_w [mm]	Material	k [mm]	Max. Load Capacity [kg]	Weight [kg]
023258	80	galvanized steel	36	16	0.21
023259	125		80		0.30
023459	125	stainless steel V4A	80	10	0.30

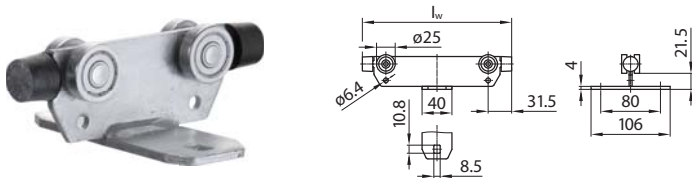

Cable Trolley Upper Parts with Buffer Order No.	l_w [mm]	Material	Max. Load Capacity [kg]	Weight [kg]
023308-125x100	125	galvanized steel	20	0.38
023308-160x100	160			0.42
023808-125x100	125	stainless steel V4A	10	0.38
023808-160x100	160			0.42

Cable Support

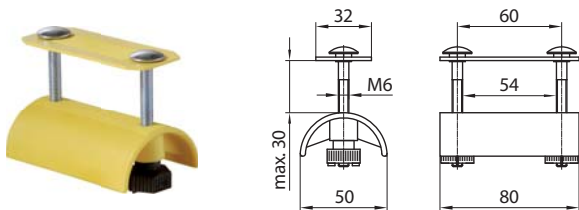

Order No. 020168

- Basic material: plastic
- Hardware: galvanized steel
- Weight: 0.06kg

Ball Joint

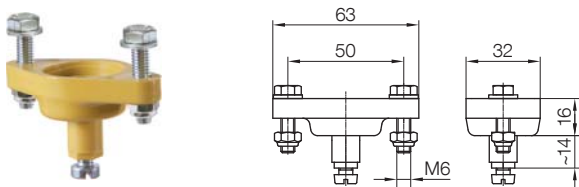

Order No. 020166

- Basic material: plastic
- Hardware: galvanized steel
- Weight: 0.035 kg

Brackets, complete

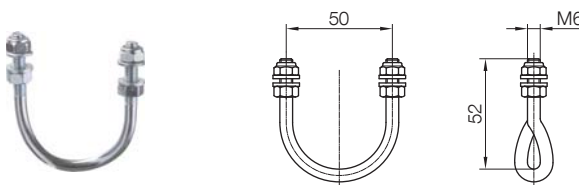

Order No.	Material	Weight [kg]
020147-50x6	galvanized steel	0.038
020447-50x6	stainless steel V4A	0.038

Design in stainless steel V4A

Accessories for Festoon Systems

Program 0230

Plastic Trolleys 2 Rollers

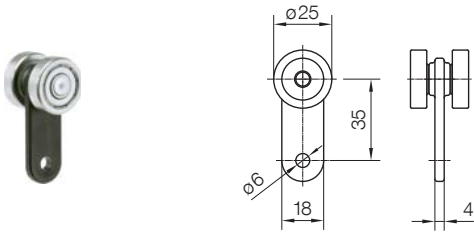

Order No.	Weight [kg]	Type of Roller	Max. Load Capacity [kg]	Max. Travel Speed [m/min]
023361	0.040	ball bearings: galvanized steel	6	20
023362	0.015	plastic roller: with friction bearing	3	

Plastic Trolleys 4 Rollers

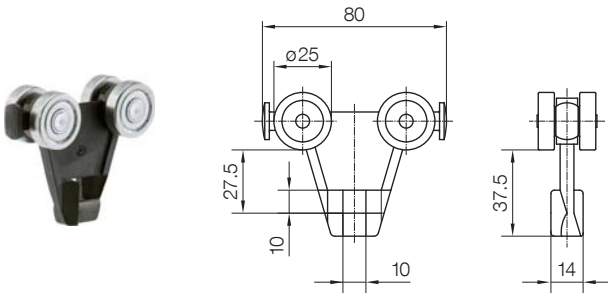

Order No.	Weight [kg]	Type of Roller	Max. Load Capacity [kg]	Max. Travel Speed [m/min]
023252	0.110	ball bearings: galvanized steel	12	32
023254	0.035	plastic roller: with friction bearing	6	

Steel Trolley 2 Rollers

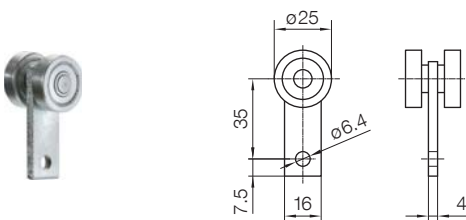

Order No. 023360

- Ball bearing: galvanized steel
- Max. load capacity: 10 kg
- Max. travel speed: 20 m/min
- Weight: 0.065 kg

Steel Trolley 4 Rollers without Buffer

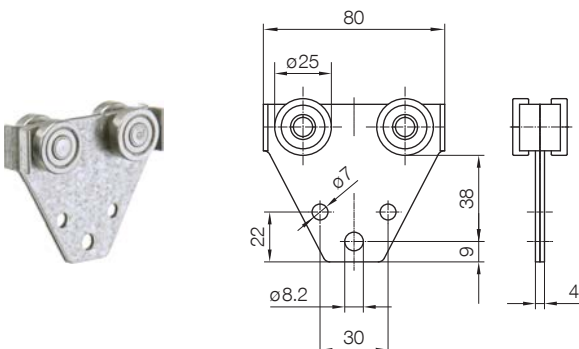

Order No. 023351

- Ball bearings: galvanized steel
- Max. load capacity: 16 kg
- Max. travel speed: 32 m/min
- Weight: 0.210 kg

Accessories for Festoon Systems Program 0230

Steel Trolley 4 Rollers with Buffer

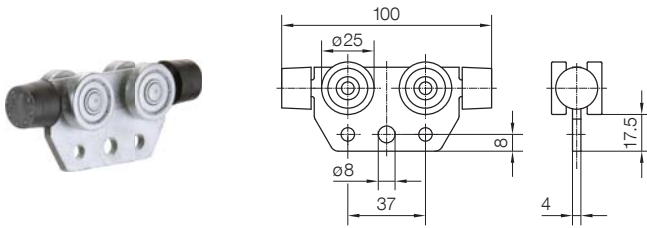

Order No. 023357-100

- Ball bearings: galvanized steel
- Max. load capacity: 20 kg
- Max. travel speed: 40 m/min
- Weight: 0.190 kg

S-Hook

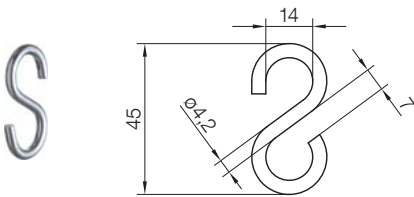

Order No. 020118-45x4

- Material: galvanized steel
- Weight: 0.016 kg

Spring Safety Hook

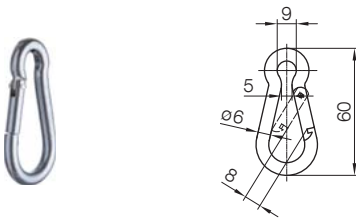

Order No. 020215-60x6

- Material: galvanized steel
- Weight: 0.030 kg

Cable Collar, Plastic

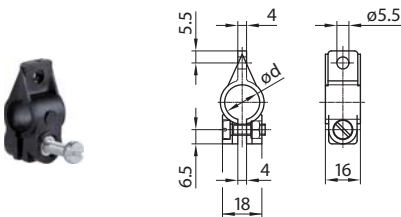

Order No.	Cable- ϕ d [mm]	Material	Weight [kg]
020111-08	8	plastic hardware: galvanized steel	0.0070
020111-10	10		0.0077
020111-11	11		0.0077
020111-12,5	12.5		0.0081
020111-14	14		0.0084
020111-16	16		0.0085
020111-18	18		0.0850
020111-20	20		0.0100
020111-22	22		0.0100
020111-25	25		0.0110
020111-28	28		0.0120
020111-32	32		0.0130
020111-36	36		0.0140

Note

For attachment to the trolley with S-hook.

Accessories for Festoon Systems

Program 0230

Strap for Cable Bundle

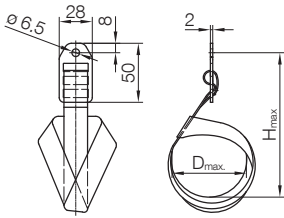

Order No.	D _{max} [mm]	H _{max} [mm]	Material	Weight [kg]
020117-080	80	150	plastic hardware: galvanized steel	0.020
020117-160	160	230		0.030

Note

For attachment to the trolley with S-hook.

Cable Clips with Bracket

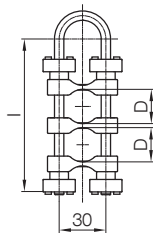

Order No.	Number of Loops n ₀	Max. Cable Diameter per Loop D [mm]	Total of all Cable Diameters Max. [mm]	l [mm]	Weight [kg]
020137-1X18	1	8-18	18	63	0.055
020137-1X22	1	8-22	22	80	0.060
020137-2X32	2	8-22	32	80	0.065
020137-2X44	2	8-22	44	100	0.070
020137-3X30	3	8-22	30	80	0.070
020137-3X66	3	8-22	66	125	0.090
020137-4X72	4	8-22	72	125	0.090
020137-5X70	5	8-22	70	125	0.095

Note

To be used in combination with trolley 023252 and 023254 on page 40.

Helpful Hints

Determination of the Load Capacity of C-Rails

Technical details / bases of calculation

The permissible load of the C-rails can be determined with the help of the diagrams. The following bases of calculation have been considered:

1. Beam on 2 supports, loaded by distributed load symmetrical to the beam center
2. $\sigma_{b_{zul}} = 100 \text{ N/mm}^2$, without consideration of the lower flange stress
3. $\sigma_V \leq 160 \text{ N/mm}^2$, reference stress from bending stress and lower flange stress
4. $f = IA/250$ allowed deflection from load and self-weight of the C-rail
5. The loading is considered symmetrically distributed over all the track supports (brackets)

Calculation example

Given:

F_{LW} = Load/trolley	5 kg
l_w = Length of cable trolley	125 mm
Z = Number of cable trolleys	5
L_b = Storage length	0.625 m
(m) = Z x l_w / 1000	

Load Diagram for C-Rail 30x32x2 (023200 / 023400 / 023404)

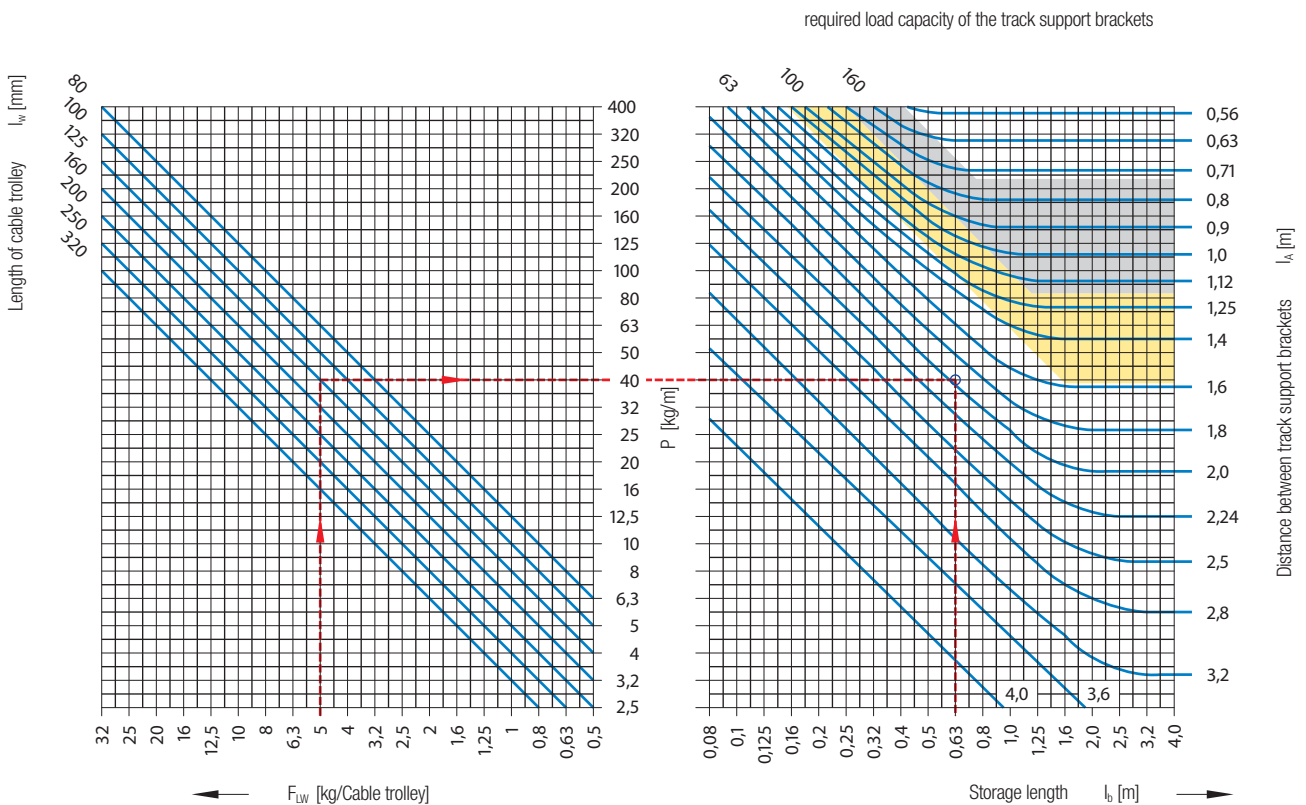

Solution for C-Rail 30x32x2

From diagram

l_b = required distance between the track support brackets = 1.95 m
 Required load capacity of the track support brackets = 63 kg

Helpful Hints

Load Diagram for C-Rail 30x32x1.5 (023201)

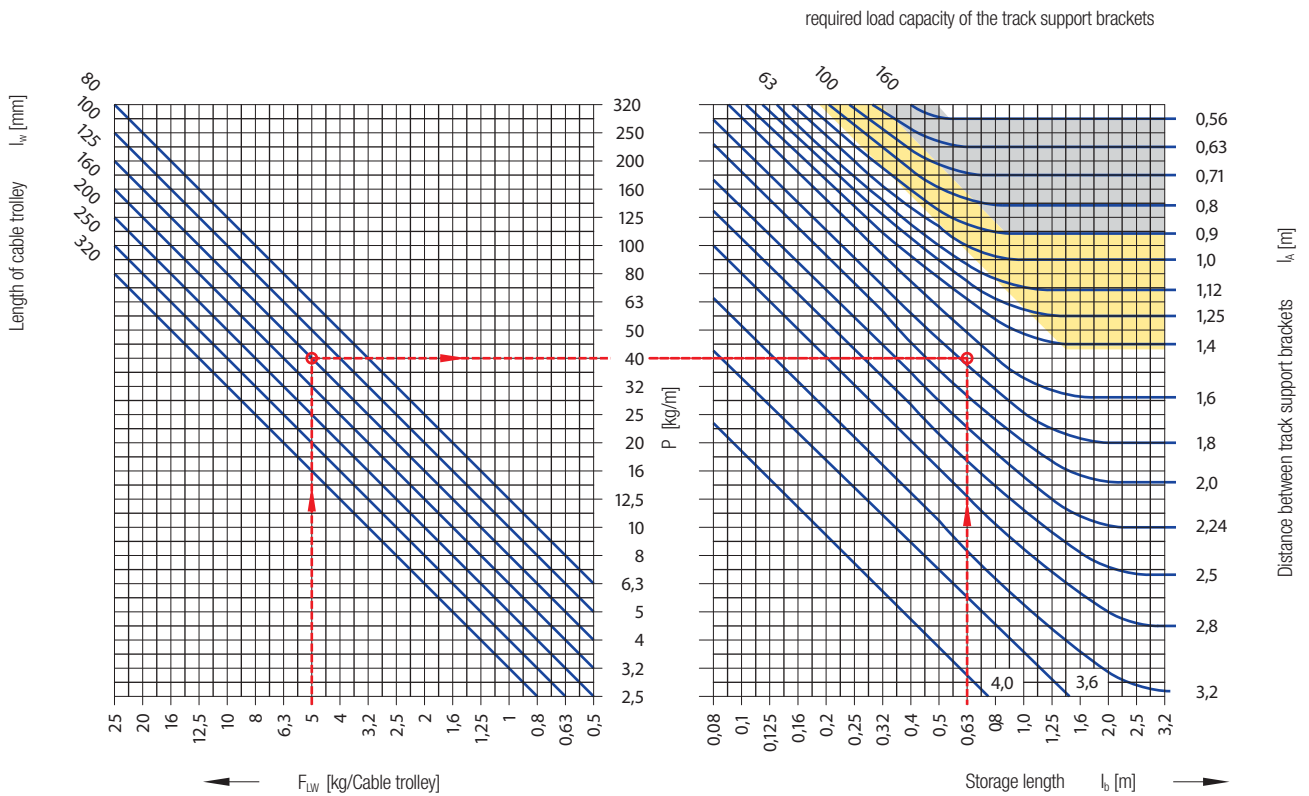

Solution for C-Rail 30x32x1.5

From diagram

l_a = required distance between the track support brackets = 1.75 m
 Required load capacity of the track support brackets = 63 kg

Helpful Hints

Technical Data

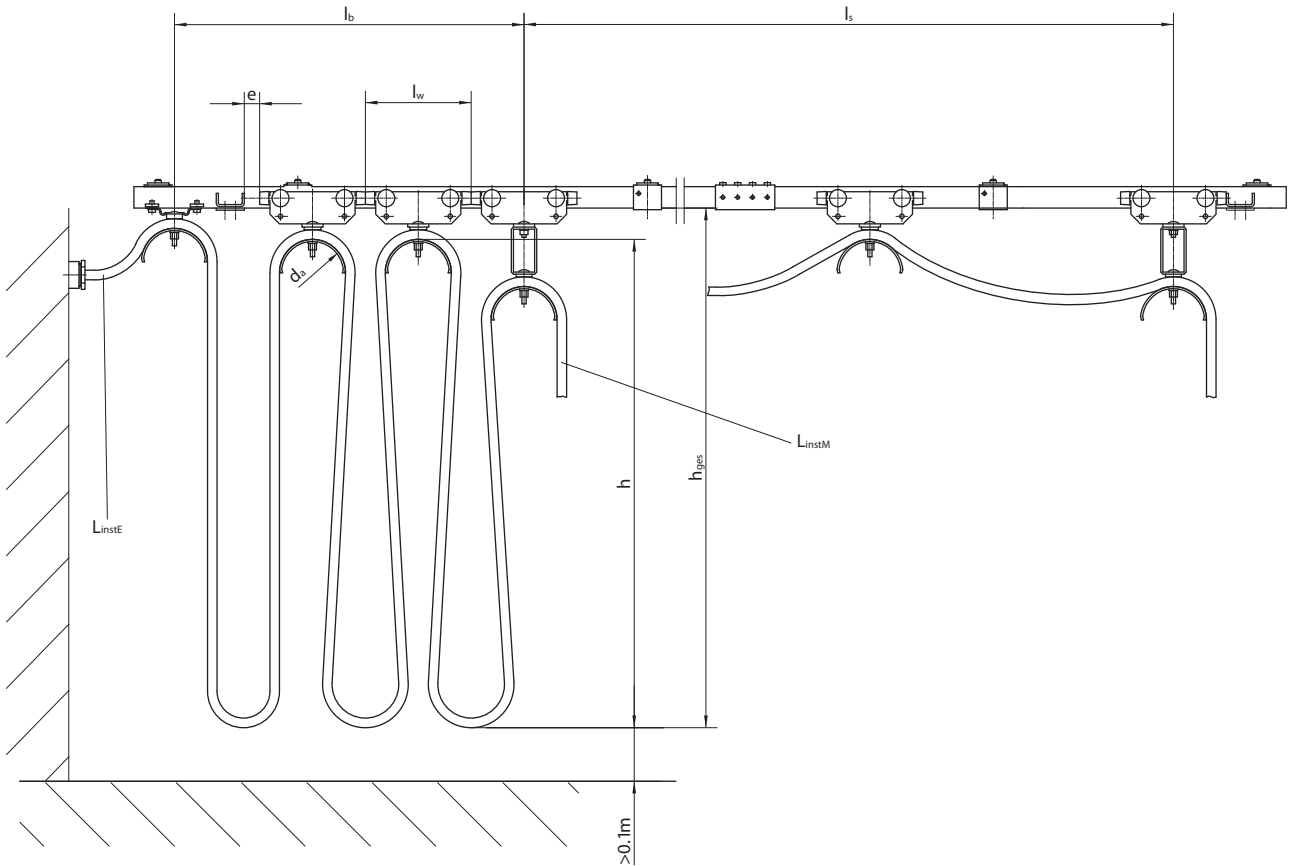

Formulas to Determine the Number of Loops, Cable Length and Loop Depth

Number of loops:

$$n = \frac{f \cdot (l_s + e)}{2 \cdot h + 1.25 \cdot d_a - f \cdot l_w}$$

Storage length:

$$l_b \approx n \cdot l_w + e \quad [\text{m}]$$

System cable length:

$$L_{\text{Syst}} = f \cdot (l_s + l_b) \quad [\text{m}]$$

Total cable length:

$$L_{\text{Best}} = L_{\text{Syst}} + L_{\text{instE}} + L_{\text{instM}} \quad [\text{m}]$$

Loop length:

$$L_{\text{Schl}} = \frac{L_{\text{Syst}}}{n} \quad [\text{m}]$$

Loop depth:

$$h = \frac{L_{\text{Schl}}}{2} - 0.63 \cdot d_a \quad [\text{m}]$$

- d_a [m] = cable support diameter
- e [m] = free space in storage area (recommendation ≥ 0.1 m)
- f = recommended cable factor (see table)
- h [m] = loop depth (measured from top edge of cable support)
- h_{ges} [m] = loop depth (measured from lower edge of cable support)
- l_b [m] = storage length incl. free space
- l_s [m] = travel distance
- l_w [m] = cable trolley length
- L_{Best} [m] = total cable length
- L_{instE} [m] = installation length, end clamp side
- L_{instM} [m] = installation length, towing side
- L_{Schl} [m] = cable length per loop
- L_{Syst} [m] = required cable length (measured from mid of end clamp to mid of towing trolley or towing clamp)
- n = number of loops

Helpful Hints

Definition of the cable arrangement and cable trolley selection

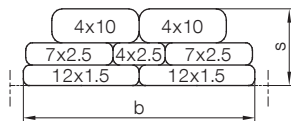

Example for flat cable trolleys

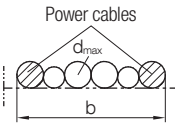

Example for round cable trolleys

1. Formula for calculating the approximate load per trolley F_{LW}

$$F_{LW} \approx 2 \cdot h \cdot G_L \quad [\text{kg}]$$

G_L [kg/m] = weight of the cable package

2. Selection of the cable trolley type
3. Required cable support diameter based upon minimum bending radius of the cables
4. Select cable support width b_2 to accommodate the cable package width
5. Determine length of trolley l_w

For round cables:

$$l_w \geq d_a + 2 \cdot d_{\max} + 10 \quad [\text{mm}]$$

For flat cables:

$$l_w \geq d_a + 2 \cdot s + 10 \quad [\text{mm}]$$

Cable Factors

Travel Speed v [m/min]	Cable Factor f at h [m]				
	< 0.8	0.8 - 1.2	1.3 - 2	2.1 - 3.2	3.3 - 5
< 32	1.10	1.10	1.10	1.10	1.10
32 - 040	1.15	1.10	1.10	1.10	1.10
41 - 050	1.20	1.15	1.10	1.10	1.10
51 - 063	1.25	1.20	1.15	1.10	1.10
64 - 080	-	1.25	1.20	1.15	1.10
81 - 100	-	-	1.25	1.20	1.15
101 - 120	-	-	-	1.25	1.20

Depending on the operating conditions the cables must be installed with an additional cable length. The additional length is calculated by taking into account the cable factor f . We recommend to select the cable factor according to above table.

For values outside the gray area, please contact us directly. Special precautions might be required in those cases under extreme operating conditions, such as the installation of shock cords.

Permissible Loads of the Rollers

Travel Speed V [m/min]	Average running time per day [h]				
	< 4	4 - 8	8 - 16	-	-
< 16	< 2	2 - 4	4 - 8	8 - 16	-
16 - 32	-	< 2	2 - 4	4 - 8	8 - 16
32 - 63	-	-	-	2 - 4	4 - 8
63 - 80	-	-	-	-	2 - 4

Type of Roller	Permissible Load of the Rollers [kg]				
	32.0	25.0	20.0	16	12.5
Ball Bearing, galvanized	16.0	12.5	10.0	8	6.3
Ball Bearing V4A	12.5	10.0	8.0	-	-
Plastic Roller with Bronze Friction Bearing	10.0	8.0	6.3	-	-

The lifetime of the rollers depends on the load (Hertzian stress) and the frequency of operation.

The proper selection, based on travel speed, average running time per day (based on one year) and permissible load of the trolleys with various roller types, can be made by using the above table.

Your Applications - our Solutions!

Festoon systems by Conductix-Wampfler represent only one of the many solutions made possible by the broad spectrum of Conductix-Wampfler components for the transport of energy, data and fluid media. The solutions we deliver for your applications are based on your specific requirements. In many cases, a combination of several different Conductix-Wampfler systems can prove advantageous. You can count on all of Conductix-Wampfler's Business Units for hands-on engineering support - coupled with the perfect solution to meet your energy management and control needs.



Cable reels

Motorized reels and spring reels by Conductix-Wampfler hold their own wherever energy, data and media have to cover the most diverse distances within a short amount of time - in all directions, fast and safe.



Festoon systems

It's hard to imagine Conductix-Wampfler cable trolleys not being used in virtually every industrial application. They're reliable and robust and available in an enormous variety of dimensions and designs.



Conductor rails

Whether they're enclosed conductor rails or expandable single-pole systems, the proven conductor rails by Conductix-Wampfler reliably move people and material.



Non-insulated conductor rails

Extremely robust, non-insulated conductor rails with copper heads or stainless steel surfaces provide the ideal basis for rough applications, for example in steel mills or shipyards.



Energy guiding chains

The "Jack of all trades" when it comes to transferring energy, data, air and fluid hoses. With their wide range, these energy guiding chains are the ideal solution for many industrial applications.

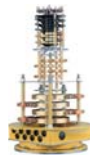

Slip ring assemblies

Whenever things are really "moving in circles", the proven slip ring assemblies by Conductix-Wampfler ensure the flawless transfer of energy and data. Here, everything revolves around flexibility and reliability!



Inductive Power Transfer IPT®

The no-contact system for transferring energy and data. For all tasks that depend on high speeds and absolute resistance to wear.



Reels, retractors and balancers

Whether for hoses or cables, as classical reels or high-precision positioning aids for tools, our range of reels and spring balancers take the load off your shoulders.



Jib boom

Complete with tool transporters, reels, or an entire media supply system - here, safety and flexibility are key to the completion of difficult tasks.



Conveyor systems

Whether manual, semiautomatic or with Power & Free – flexibility is achieved with full customization concerning layout and location.

www.conductix.com

Conductix-Wampfler AG

Rheinstrasse 27+33
79576 Weil am Rhein
Germany

Hotline

Phone +49 (0) 7621 662-222

Phone +49 (0) 7621 662-0

Fax +49 (0) 7621 662-144

info.de@conductix.com

www.conductix.com



DELACHAUX GROUP